



Tonino Lamborghini

TOTAL LIVING



Tonino Lamborghini

TOTAL LIVING

BOLD DESIGN

REINVENTED TRADITION

Bold design, reinvented tradition:

An immersive journey where luxury meets innovation and Italian craftsmanship.

The FRAME collection by Giò Forma fuses high-performance mechanics, art and technology with bold design, while the FAST FORWARD collection by Ricardo Antonio offers geometric elegance and solidity.

Both celebrate Mr. Tonino Lamborghini's heritage and the essence of Italian excellence.

Bold design, reinvented tradition:

Un viaggio coinvolgente dove il lusso incontra l'innovazione e l'artigianato italiano.

La collezione FRAME di Giò Forma fonde meccanica ad alte prestazioni, arte e tecnologia con un design audace, mentre la collezione FAST FORWARD di Ricardo Antonio offre eleganza geometrica e solidità.

Entrambe celebrano il patrimonio del Dott. Tonino Lamborghini e l'essenza dell'eccellenza italiana.

FRAME COLLECTION

BY GIÒ FORMA

Sofa - BOLD FRAME	12
Lounge Sofa - BENCH FRAME	18
Armchair - BIG FRAME	24
Chaise Longue - LONG FRAME	30
Chair - DINING FRAME	36
Table - TOP FRAME	42
Bookcase - BOOKWALL FRAME	48
Room Divider - SCREEN FRAME	54
Bed - NIGHT FRAME	60



BOLD FRAME

BOLD is a confident, sculptural sofa that combines angular geometry and comfort. Velvet makes it enveloping while leather piping emphasizes its audacious character.

BOLD è un divano scultoreo e deciso che combina geometrie spigolose e comfort. Il velluto lo rende avvolgente mentre il piping in pelle ne sottolinea il carattere audace.



BOLD FRAME

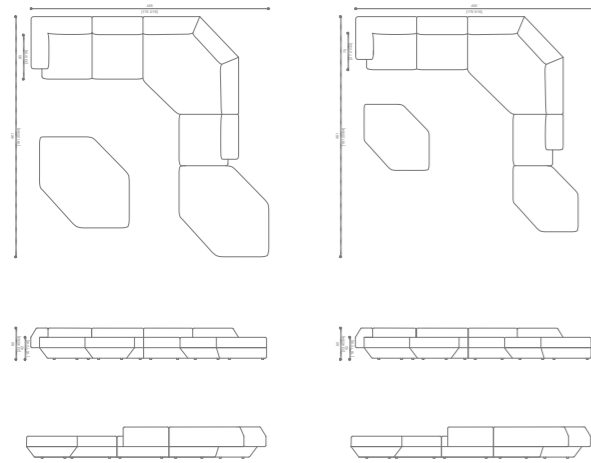

Sofa with pine plywood and poplar plywood frame; polyurethane foam padding with differentiated densities. The whole frame is upholstered in velvet, with a leather piping.

Divano con struttura in multistrato di legno di pino e compensato di legno di pioppo; imbottitura in poliuretano espanso a densità differenziate. Tutta la struttura è rivestita in velluto, con una proflatura in pelle.





BENCH FRAME

Anodized aluminum frame and leather upholstery for a dynamic and modern design. An elegant and minimalist bench that combines solidity and style with contemporary lightness.

Struttura in alluminio anodizzato e rivestimento in pelle per un design dinamico e moderno. Un bench elegante e minimale, che unisce solidità e stile con leggerezza contemporanea.



BENCH FRAME

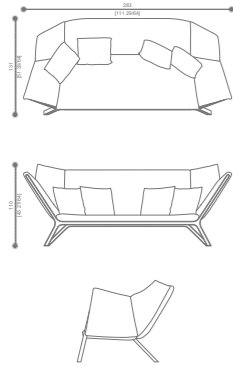

Anodized aluminum frame, polyurethane foam padding with differentiated densities.
Leather upholstery.

*Struttura in alluminio anodizzato, imbottitura in poliuretano espanso a densità differenziate.
Rivestimento in pelle.*





BIG FRAME

Symbol of the line, the Big Armchair is an armchair with deliberately important dimensions, a true transport capsule, a refuge for an elegant, powerful and bold journey. A timeless object, but with an eye to the future.

Simbolo della linea, la poltrona Big è una poltrona dalle dimensioni volutamente importanti, una vera e propria capsula di trasporto, un rifugio per un viaggio elegante, potente e audace. Un oggetto timeless, ma con lo sguardo rivolto al futuro.



BIG FRAME

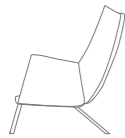
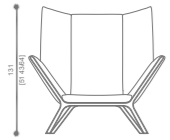
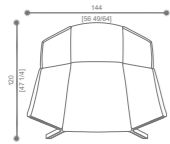

Anodized aluminum frame, polyurethane foam padding with differentiated densities.
Leather upholstery.

*Struttura in alluminio anodizzato, imbottitura in poliuretano espanso a densità differenziate.
Rivestimento in pelle.*





LONG FRAME

Light design, enveloping form. The chaise longue combines soft curves and solid anodized aluminum frame, upholstered in leather for luxurious and sophisticated comfort.

Leggera nelle linee, avvolgente nella forma. La chaise longue combina curve morbide e struttura solida in alluminio anodizzato, rivestita in pelle per un comfort lussuoso e sofisticato.



LONG FRAME

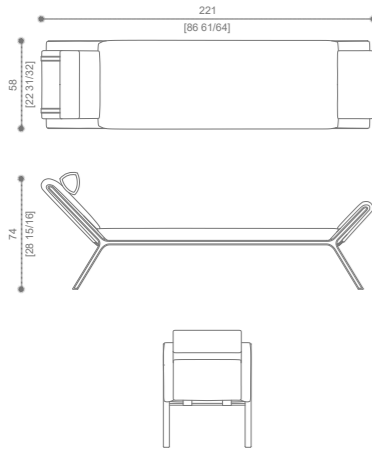

Anodized aluminum frame, polyurethane foam padding with differentiated densities.
Leather upholstery.

*Struttura in alluminio anodizzato, imbottitura in poliuretano espanso a densità differenziate.
Rivestimento in pelle.*





DINING FRAME

An aluminum frame meets fine upholstery. Clean lines and sophisticated angles shape a versatile design between sporty elegance and industrial spirit.

Una struttura in alluminio incontra rivestimenti pregiati. Linee pulite e angoli sofisticati danno forma a un design versatile, tra eleganza sportiva e spirito industriale.



DINING FRAME

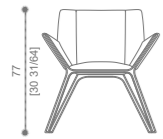
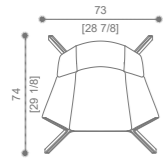

Anodized aluminum frame, polyurethane foam padding with differentiated densities. Leather upholstery.

Struttura in alluminio anodizzato, imbottitura in poliuretano espanso a densità differenziate. Rivestimento in pelle.





TOP FRAME

Sharp lines, bold proportions and sculptural presence: a 4-seater dining table that focuses on essential elegance with contemporary character.

Linee nette, proporzioni decise e presenza scultorea: un tavolo da pranzo a 4 posti che punta sull'eleganza essenziale con carattere contemporaneo.



TOP FRAME

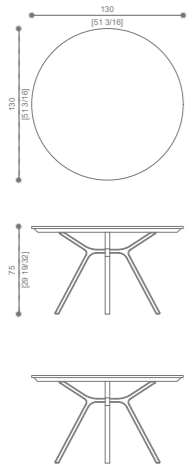

Dining table with
glass, smoked glass or
canaletto walnut wood
top. Anodized aluminum
frame.

*Tavolo da pranzo con top
vetro, vetro fumé o legno
noce canaletto. Struttura
in alluminio anodizzato.*





BOOKWALL

A three-dimensional grid that represents a perfect marriage of architectural language and engineering spirit; a design that combines lightness, bold lines and solidity.

Una griglia tridimensionale che rappresenta un perfetto connubio tra linguaggio architettonico e spirito ingegneristico; un design che unisce leggerezza, linee decise e solidità.



BOOKWALL

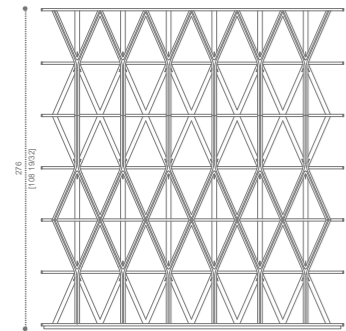
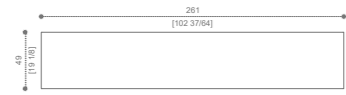

Bookcase with canaletto walnut frame and leather-covered shelves. Finishes and details in anodised aluminium.

Libreria con struttura in noce canaletto e mensole rivestite in pelle. Finiture e dettagli in alluminio anodizzato.

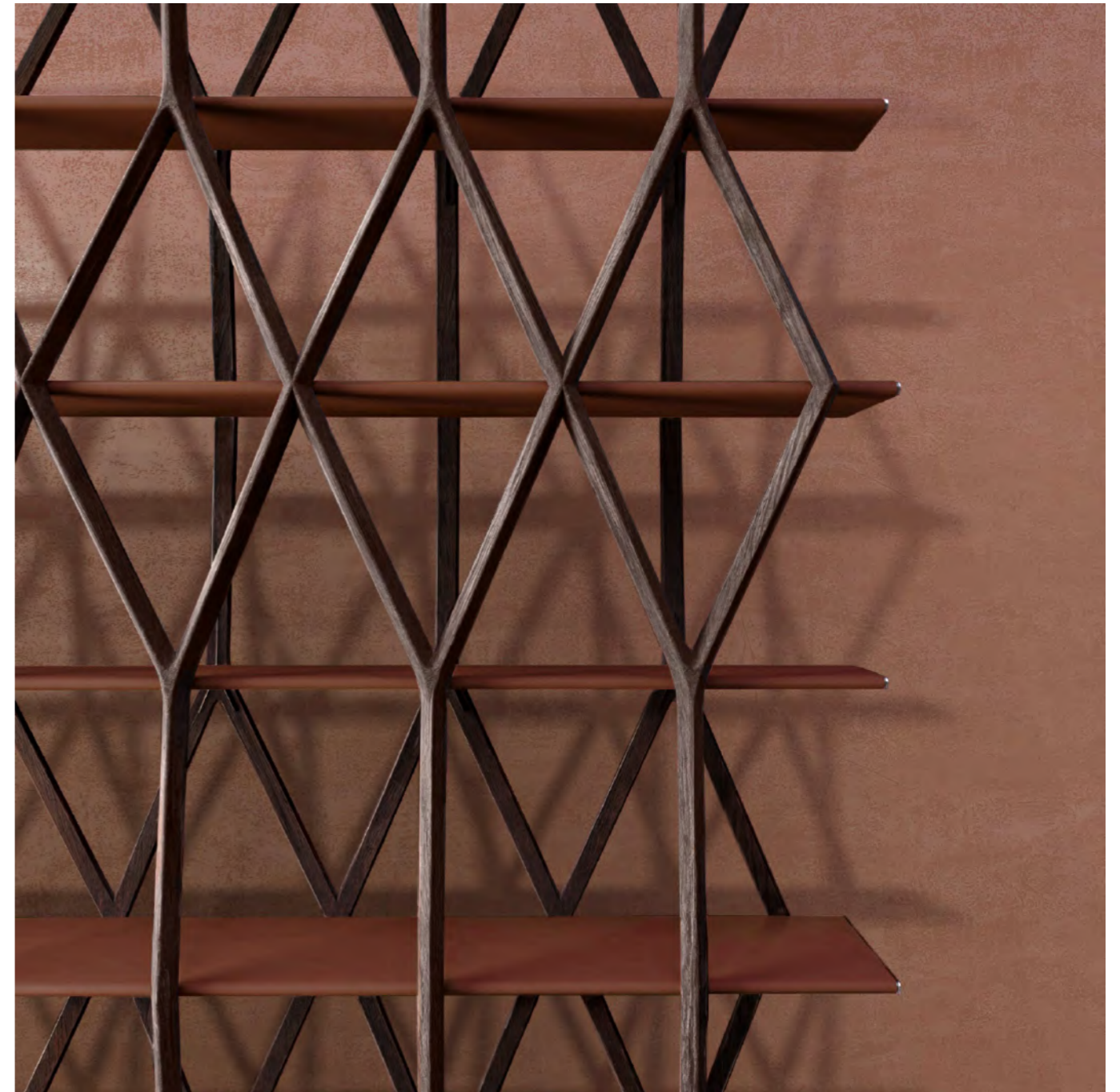



SCREEN FRAME

Three layers of leather weave, inspired by Tonino Lamborghini's geometries, create an impactful screen that divides, furnishes and captures the eye.

Tre livelli di intreccio in pelle, ispirati alle geometrie di Tonino Lamborghini, danno vita a un paravento d'impatto che divide, arreda e cattura lo sguardo.



SCREEN FRAME

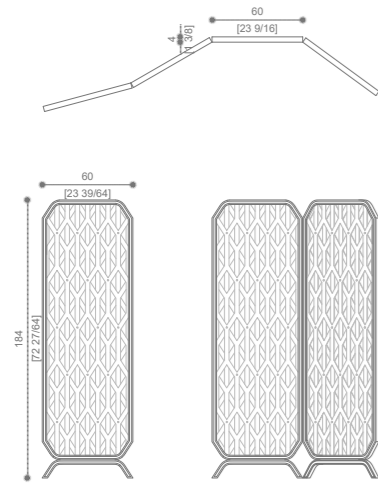

Anodised aluminium
frame, leather weave.

*Struttura in alluminio
anodizzato, intreccio in
pelle.*





NIGHT FRAME

Inclined lines and horizontal proportions define the slender profile of NIGHT. A bed with a strong, solid and dynamic mark, combining monumentality and elegance.

Linee inclinate e proporzioni orizzontali definiscono il profilo slanciato di NIGHT. Un letto dal segno deciso, solido e dinamico, che unisce monumentalità ed eleganza.



NIGHT FRAME

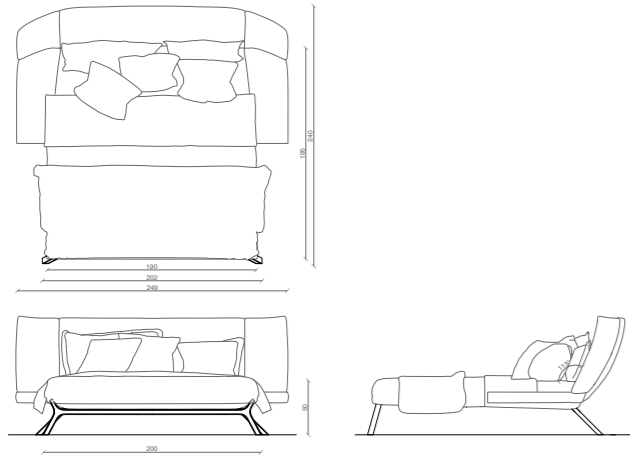

Bed with anodised aluminium frame, padding in differentiated density polyurethane foam, leather upholstery.

Letto con struttura in alluminio anodizzato, imbottitura in poliuretano espanso densità differenziate, rivestimento in pelle.



Founded in 1998 in Milan by Cristiana Picco, Florian Boje, and Claudio Santucci, Giò Forma is a leading design, art, and architecture studio known for bold, multidisciplinary work in architecture, stage design, and immersive experiences.

From Expo 2015's Tree of Life to the Maraya Concert Hall, the world's largest mirrored building and The Chedi hotel in Hegra, Giò Forma has shaped global cultural landmarks with its innovative approach.

The studio collaborates across industries—architecture, hospitality, fashion, and entertainment—delivering standout projects for Gucci, Giorgio Armani and Bulgari, as well as La Scala, the Bolshoi Theatre, and Sydney Opera House.

Its expertise spans concerts, luxury brand showcases, and major international events.

Now, Giò Forma and Strong by Form combine visionary design and material innovation to launch an acoustic panel collection, leveraging Giò Forma's creative excellence and Woodflow's unique flexibility to redefine aesthetics and performance in interior spaces.

Fondato nel 1998 a Milano da Cristiana Picco, Florian Boje e Claudio Santucci, Giò Forma è uno studio leader nel campo del design, dell'arte e dell'architettura, noto per il suo lavoro audace e multidisciplinare in architettura, scenografia ed esperienze immersive.

Dall'Albero della Vita dell'Expo 2015 alla Maraya Concert Hall, l'edificio a specchi più grande del mondo, fino all'hotel The Chedi di Hegra, Giò Forma ha realizzato punti di riferimento culturali globali con il suo approccio innovativo.

Lo studio collabora con diversi settori – architettura, ospitalità, moda e intrattenimento – realizzando progetti di spicco per Gucci, Giorgio Armani e Bulgari, così come per il Teatro alla Scala, il Teatro Bolshoi e la Sydney Opera House.

La sua esperienza comprende concerti, vetrine di marchi di lusso e grandi eventi internazionali.

Ora, Giò Forma e Strong by Form uniscono design visionario e innovazione dei materiali per lanciare una collezione di pannelli acustici, sfruttando l'eccellenza creativa di Giò Forma e la flessibilità unica di Woodflow per ridefinire l'estetica e le prestazioni degli spazi interni.

GIO FORMA
STUDIO ASSOCIATO Srl

Via Sigieri 24, 20135 Milano (MI)
C.F. / P.IVA 03708400969
T: (39) 02 54118494
gioforma@gioforma.com

**FAST FORWARD
COLLECTION**
BY RICARDO ANTONIO

The FAST FORWARD collection, designed by Ricardo Antonio, offers a geometric and contemporary aesthetic that combines structural solidity and refinement. A complete journey through constellations, harmonious and stately pieces.

La collezione FAST FORWARD, progettata da Ricardo Antonio, offre un'estetica geometrica e contemporanea che unisce solidità strutturale e raffinatezza. Un viaggio completo attraverso costellazioni, pezzi armoniosi e maestosi.

ABSOLUT

Absolut Sofa 76

Absolut Curved Sofa 80

Absolut Armchair 84

Absolut Bench 88

Absolut Pouf 92

Absolut Coffee Table 96

Absolut Bed 100

Absolut Chaise Longue 104

Absolut Bookcase 108

Absolut Bed Side Table 112

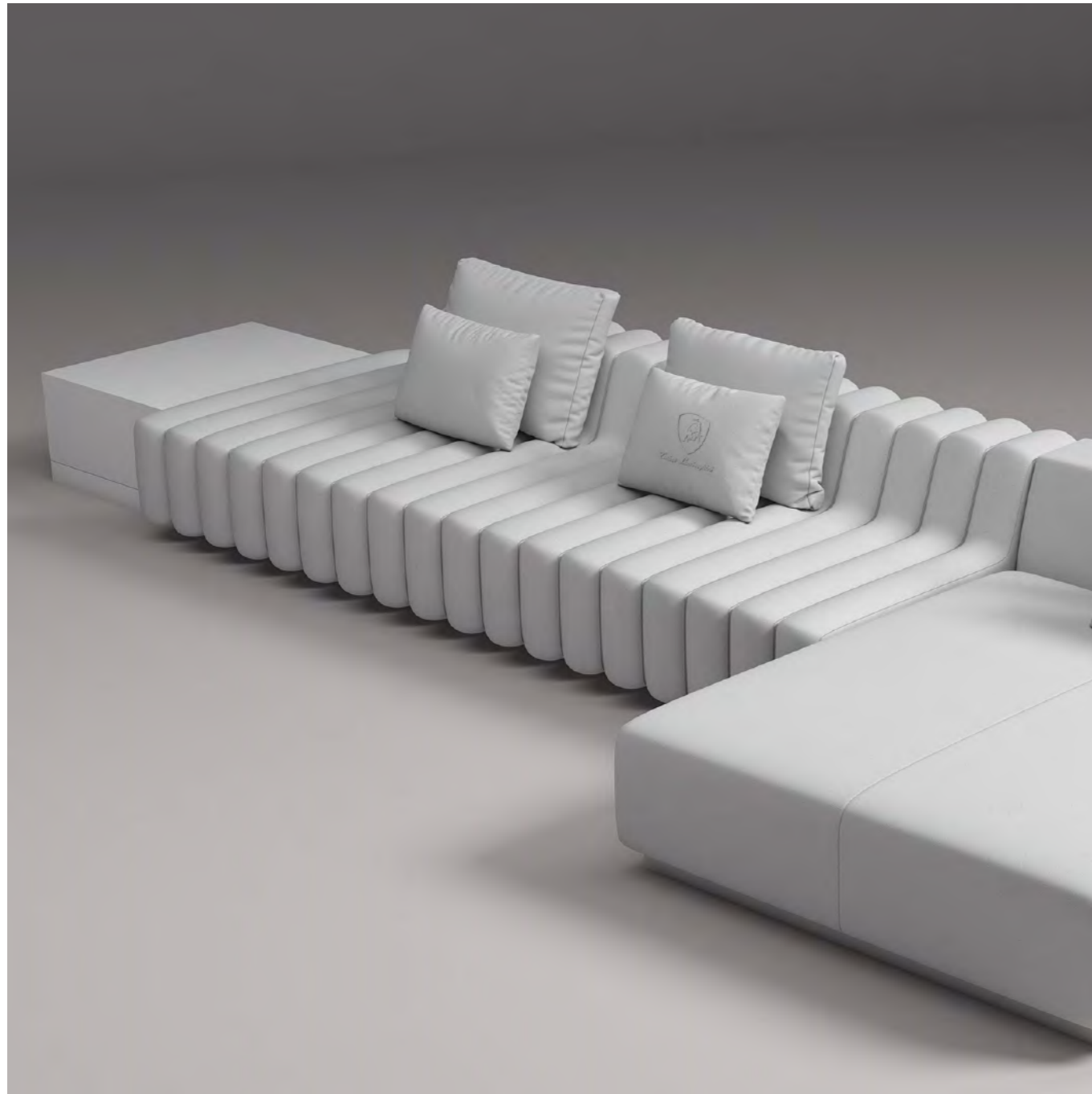

ABSOLUT SOFA

A modular sofa system that combines comfort and sculptural design. Armrests and backs are brought to life by soft quilting that creates semi-cylinders juxtaposed one against the other, giving dynamism. Ergonomic, cozy seating is made with high-quality materials and exclusive upholstery in fabrics or fine leathers from the collection. The modularity options, with regular or curved shapes, allow different configurations to be created, always resulting in a strong scenic impact.

Un sistema di divani componibili che unisce comfort e design scultoreo. Braccioli e schienali sono animati da morbide trapuntature che creano semi cilindri accostati uno all'altro, conferendo dinamismo. Le sedute ergonomiche e accoglienti sono realizzate con materiali di alta qualità e rivestimenti esclusivi in tessuti o pelli pregiate della collezione. Le opzioni di componibilità, con forme regolari o curve, permettono di creare diverse configurazioni, per un risultato sempre di forte impatto scenico.

**ABSOLUT
SOFA**

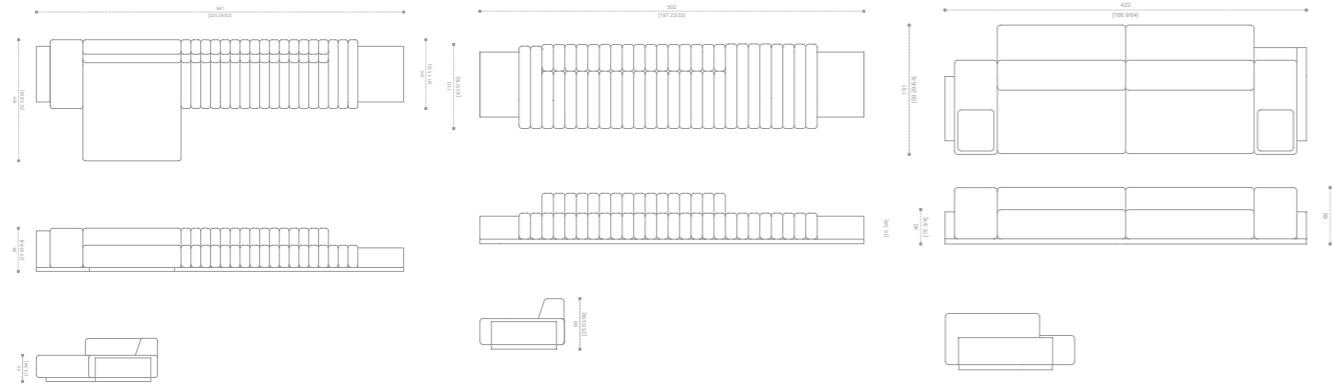

Sofa with solid/plywood frame and painted/lacquered MDF frame, padding in multi-density high resilience polyurethane foam. Leather or fabric upholstery.

Divano con struttura in legno massello/ multistrato e struttura verniciata/laccata in MDF, imbottitura in poliuretano espanso a densità differenziate, rivestimento in pelle o tessuto.

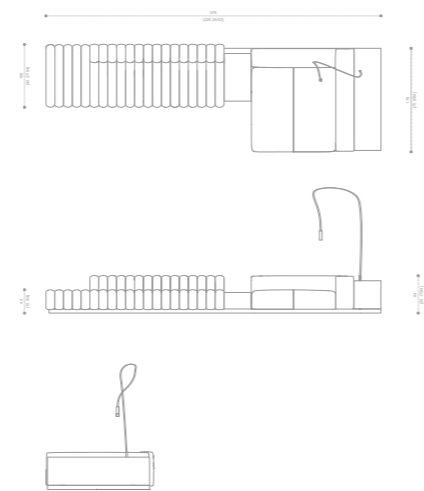

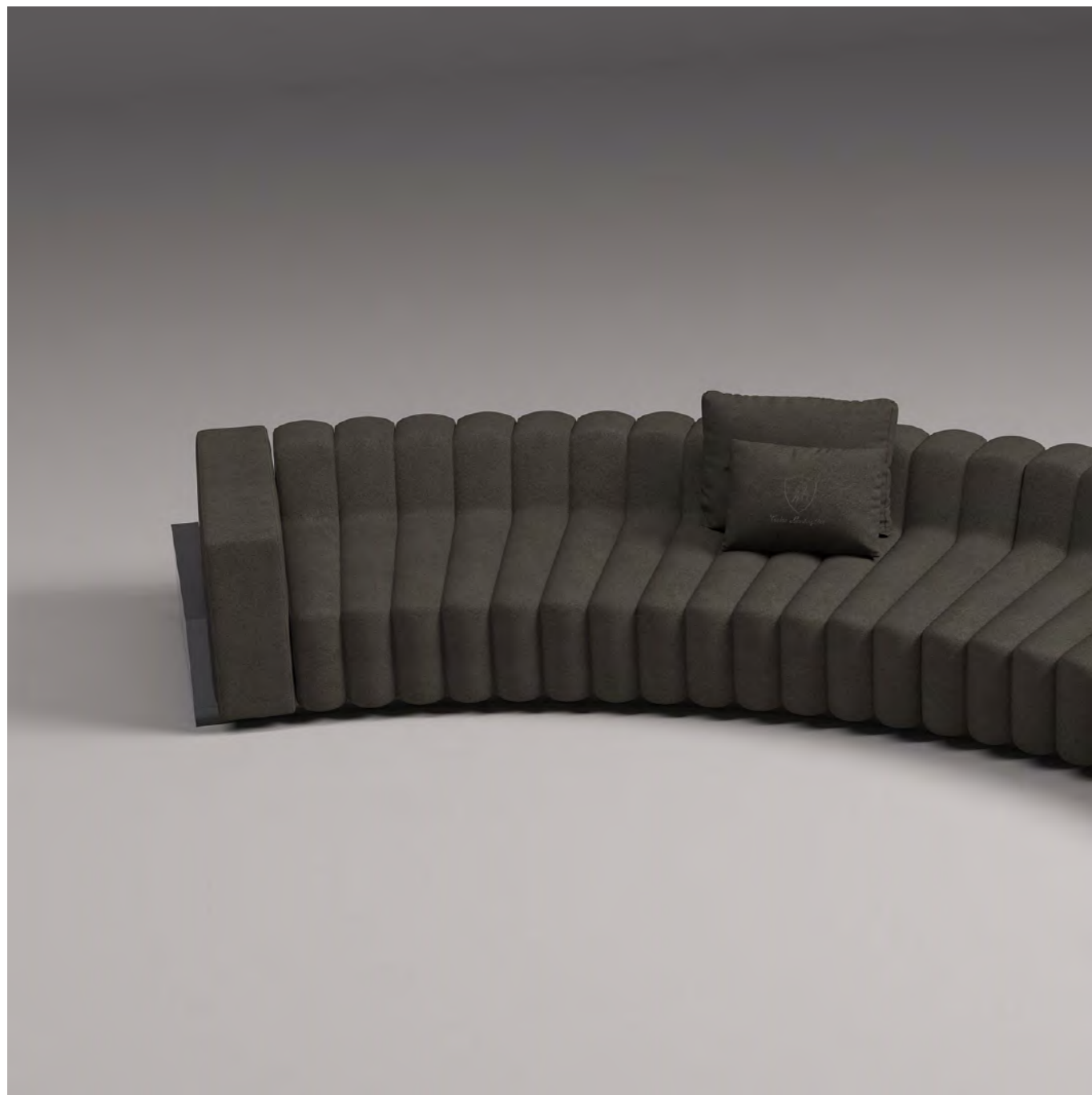

ABSOLUT CURVED SOFA

The Absolut sofa redefines the concept of comfort with a bold and dynamic aesthetic. Its sinuous curve seems to sculpt space, creating a dialogue between fluidity and solidity, between comfort and architectural rigour. The design, inspired by organic forms but with geometric precision, transforms the sofa into a sculptural element, capable of dominating the environment with elegance and personality. Exclusive materials and refined finishes enhance the contrast between softness and structure, offering a unique visual and tactile experience. An evolutionary interpretation of contemporary luxury, where design is not just seen, but lived.

Il divano Absolut ridefinisce il concetto di comfort con un'estetica audace e dinamica. La sua curva sinuosa sembra scolpire lo spazio, creando un dialogo tra fluidità e solidità, tra accoglienza e rigore architettonico. Il design, ispirato a forme organiche ma con una precisione geometrica, trasforma il divano in un elemento scultoreo, capace di dominare l'ambiente con eleganza e personalità. Materiali esclusivi e finiture raffinate esaltano il contrasto tra morbidezza e struttura, offrendo un'esperienza visiva e tattile unica. Un'interpretazione evolutiva del lusso contemporaneo, dove il design non si limita a essere visto, ma vissuto.

**ABSOLUT
CURVED SOFA**

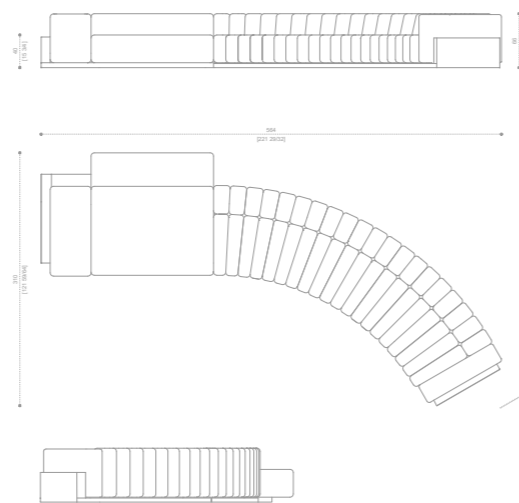
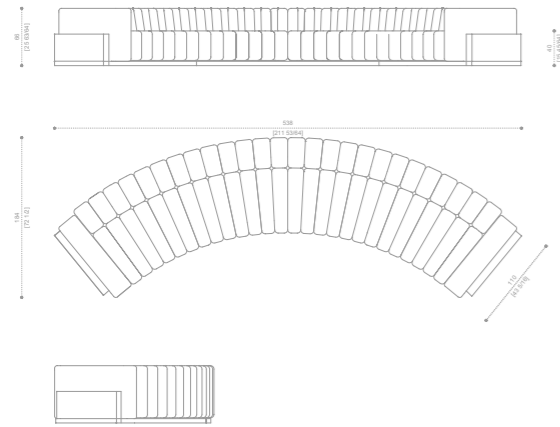

Curved modular sofa with solid/plywood frame and painted/lacquered MDF frame, padding in multi-density high resilience polyurethane foam. Leather or fabric upholstery.

Divano curvo componibile, con struttura in legno massello/multistrato e struttura verniciata/laccata in MDF, imbottitura in poliuretano espanso densità differenziate, rivestimento in pelle o tessuto.





ABSOLUT ARMCHAIR

The armchair in the Absolut line echoes the iconic sofa design, with armrests and backs decorated with tailored quilting forming raised semi-cylinders. The cozy proportions and sculpted lines make it a perfect choice for those seeking comfort and style in one piece. An object with a disruptive personality.

La poltrona della linea Absolut riprende l'iconico design del divano, con braccioli e schienali decorati da trapuntature sartoriali che formano semi cilindri in rilievo. Le proporzioni accoglienti e le linee scolpite la rendono una scelta perfetta per chi cerca comfort e stile in un unico pezzo. Un oggetto dalla personalità dirompente.

**ABSOLUT
ARMCHAIR**

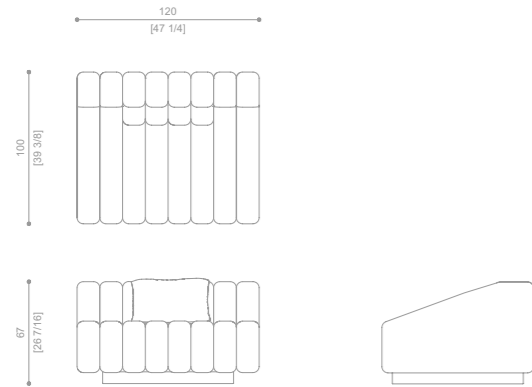

Armchair solid/plywood frame and painted/lacquered MDF frame, swivel base in painted wood, padding in multi-density high resilience polyurethane foam. Leather or fabric upholstery.

Poltrona con struttura in legno massello/multistrato e struttura verniciata/laccata in MDF, base girevole in legno verniciato, imbottitura in poliuretano espanso densità differenziate, rivestimento in pelle o tessuto.



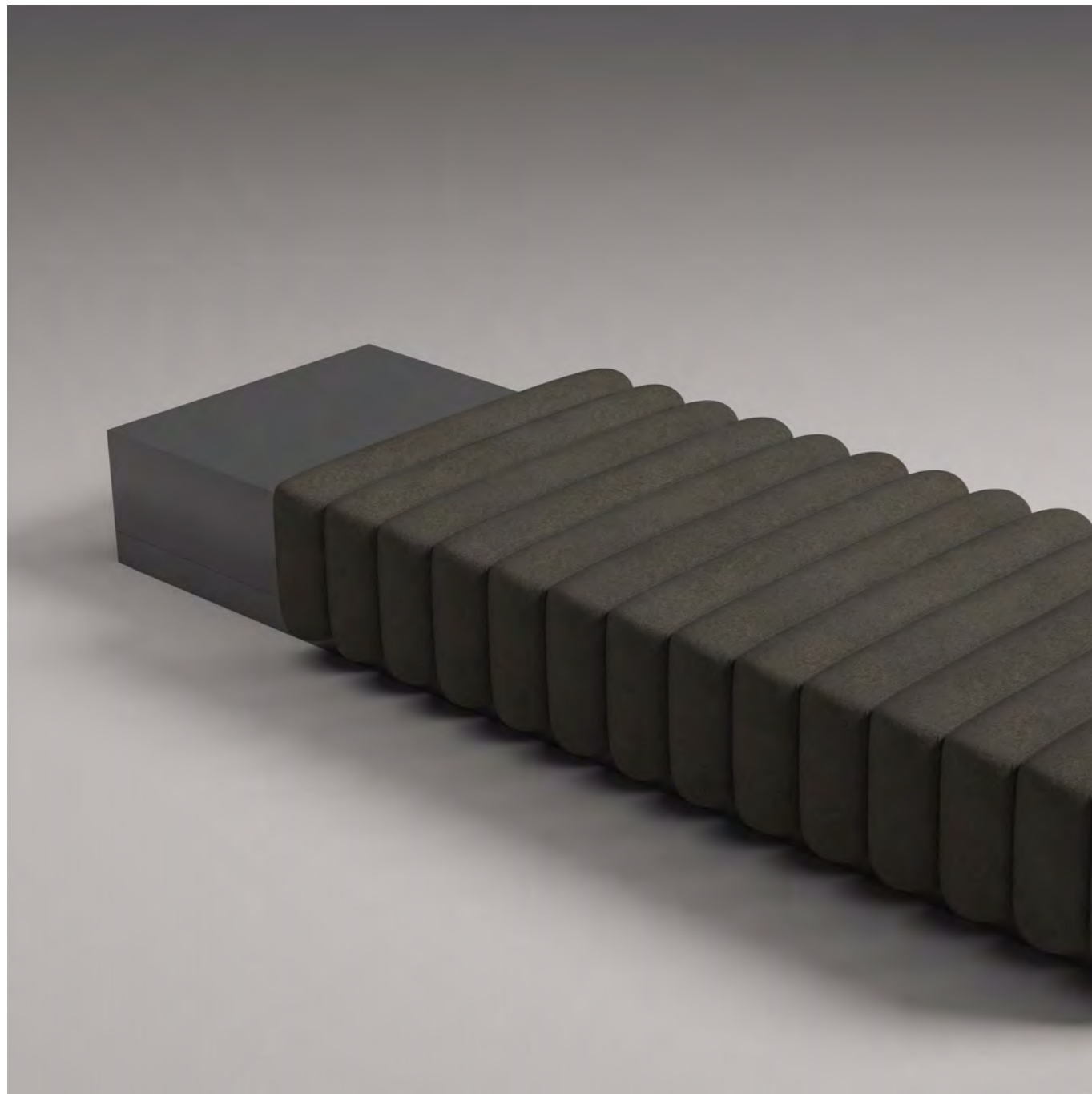

ABSOLUT BENCH

Pure lines and sculpted volume meet in the Absolut Bench, which embodies a decisive, contemporary elegance. The structure, compact and rigorous, is modelled like an architectural block, but with soft and inviting proportions. The large, continuous upper surface is embellished with padded half-cylinders that punctuate the visual rhythm with sartorial precision. Every detail, from the stitching to the choice of materials, is designed to convey a sense of visual solidity and tactile refinement. An element that combines form and function, designed to dialogue with space with character and measure.

Linee pure e volume scolpito si incontrano nella Absolut Bench, che incarna un'eleganza decisa e contemporanea. La struttura, compatta e rigorosa, è modellata come un blocco architettonico, ma con proporzioni morbide e invitanti. La superficie superiore, ampia e continua, è impreziosita da una lavorazione a semi cilindri imbottiti che scandisce il ritmo visivo con precisione sartoriale. Ogni dettaglio, dalle cuciture alla scelta dei materiali, è pensato per restituire un senso di solidità visiva e raffinatezza tattile. Un elemento che unisce forma e funzione, pensato per dialogare con lo spazio con carattere e misura.

**ABSOLUT
BENCH**

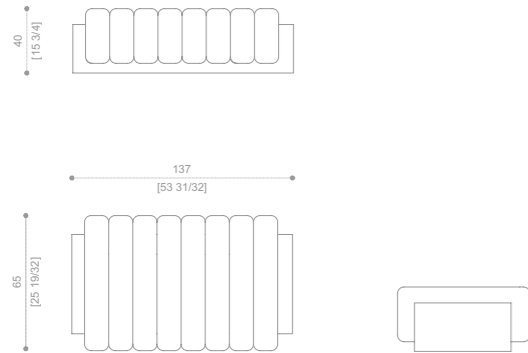

Bench with solid/
plywood frame and
painted/lacquered
MDF frame, padding
in multi-density high
resilience polyurethane
foam. Leather or fabric
upholstery.

*Panca con struttura
in legno massello/
multistrato e struttura
verniciata/laccata in
MDF, imbottitura in
poliuretano espanso
densità differenziate,
rivestimento in pelle o
tessuto.*

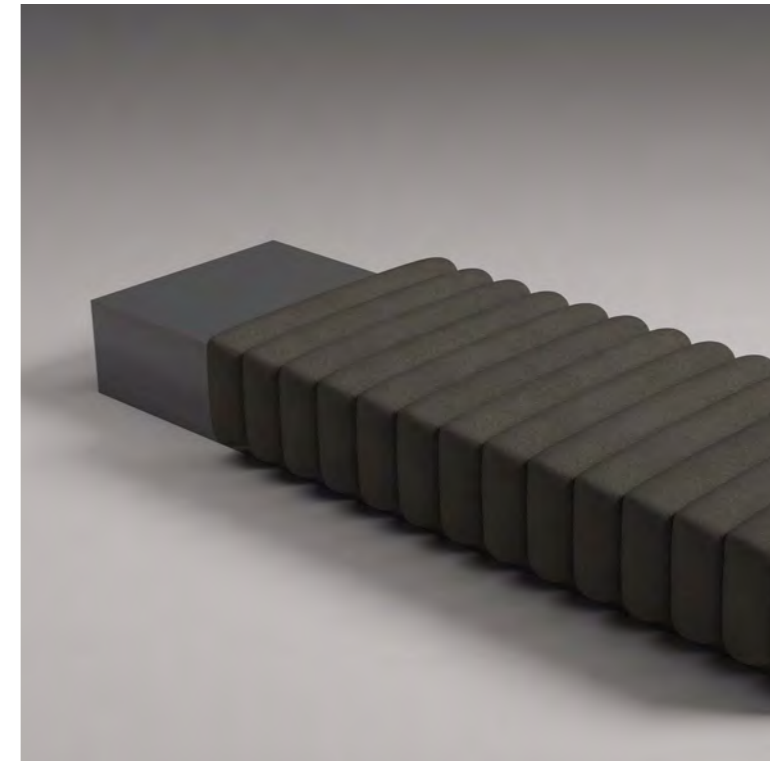



ABSOLUT POUF

An essential volume that encapsulates all the expressive power of the Absolut line. The pouf, with its generous proportions and sculptural forms, echoes the iconic motif of the upholstered half-cylinder, creating a perfect balance between compactness and softness. Its versatility makes it an ideal complement, capable of adding a touch of sophisticated modernity to spaces.

Un volume essenziale che racchiude tutta la forza espressiva della linea Absolut. Il pouf, dalle ampie proporzioni e dalle forme scolpite, riprende l'iconico motivo dei semi cilindri imbottiti, creando un equilibrio perfetto tra compattezza e morbidezza. La sua versatilità lo rende un complemento ideale, capace di aggiungere un tocco di sofisticata modernità agli spazi.

**ABSOLUT
POUF**

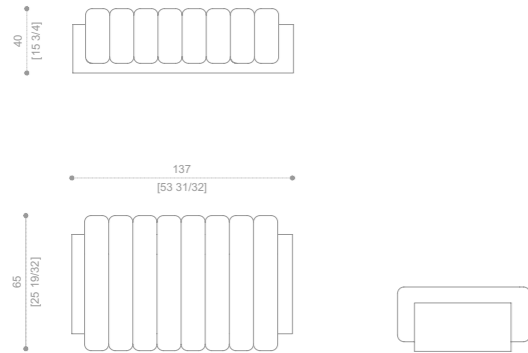

**Pouf with solid/
plywood frame and
painted/lacquered
MDF frame, padding
in multi-density high
resilience polyurethane
foam. Leather or fabric
upholstery.**

*Pouf con struttura
in legno massello/
multistrato e struttura
verniciata/laccata in
MDF, imbottitura in
poliuretano espanso
densità differenziate,
rivestimento in pelle o
tessuto.*



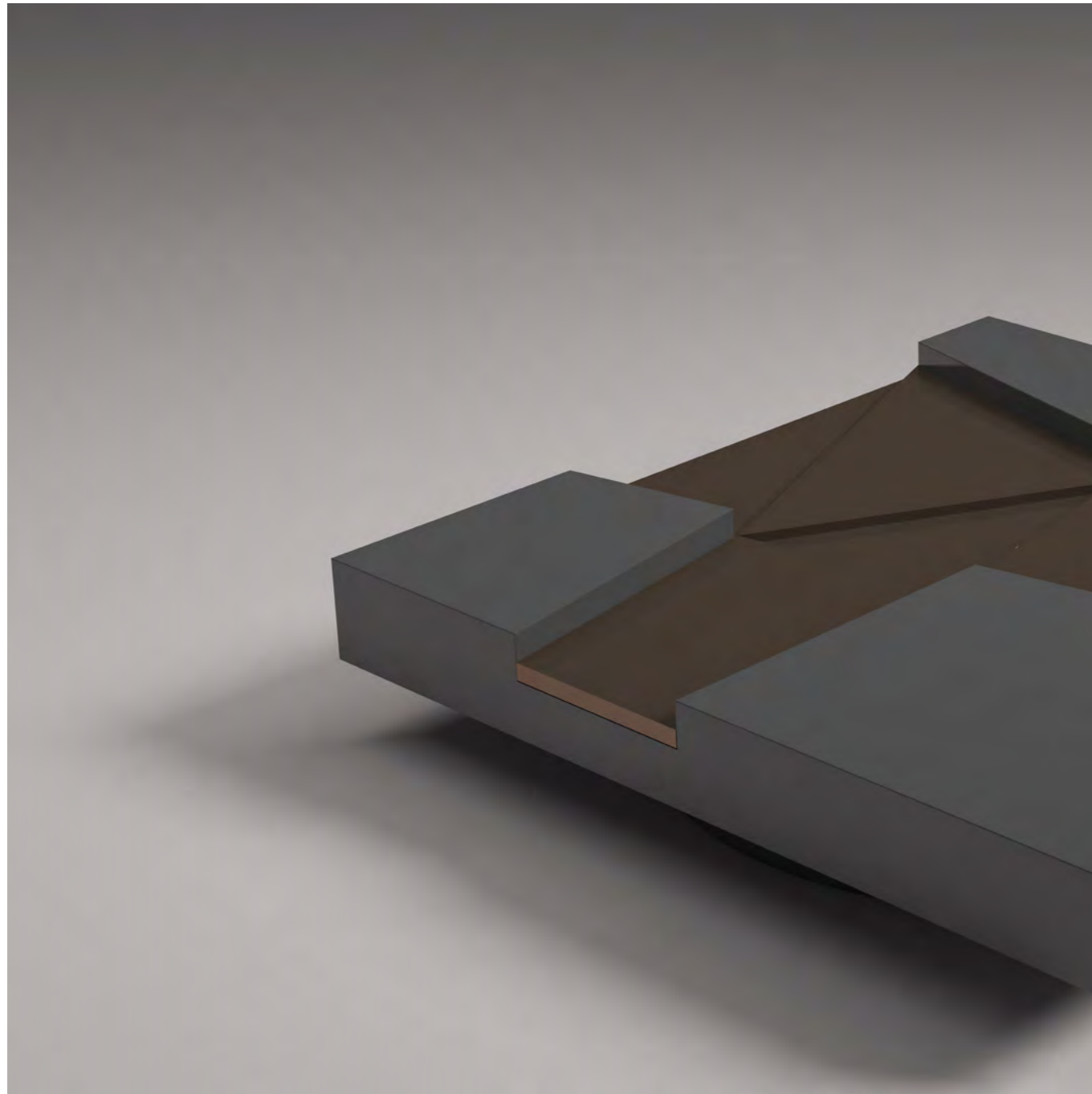

ABSOLUT COFFEE TABLE

Sculptural work that dominates space. The large Absolut low table features a rectangular structure made of fine wood essence, worked through an innovative process of subtraction of volumes. The geometries carved into it create a bold design, transforming it into a piece of furniture with a strong visual impact. It is the perfect answer for those who prefer contemporary settings, where every detail is decisive.

Opera scultorea che domina lo spazio. Il tavolo basso Absolut, di grandi dimensioni, è caratterizzato da una struttura rettangolare in essenza di legno pregiata, lavorata attraverso un innovativo processo di sottrazione di volumi. Le geometrie scavate al suo interno creano un design audace, trasformandolo in un elemento d'arredo di forte impatto visivo. È la risposta perfetta per chi predilige ambienti contemporanei, dove ogni dettaglio è decisivo.

**ABSOLUT
COFFEE TABLE**

110 145
[43 5/16] [56 15/16]

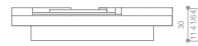
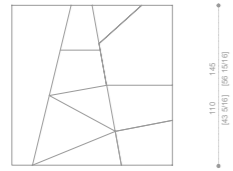

Coffee table with
structure in painted/
lacquered MDF.

*Tavolino con struttura in
MDF vernicato/laccato.*

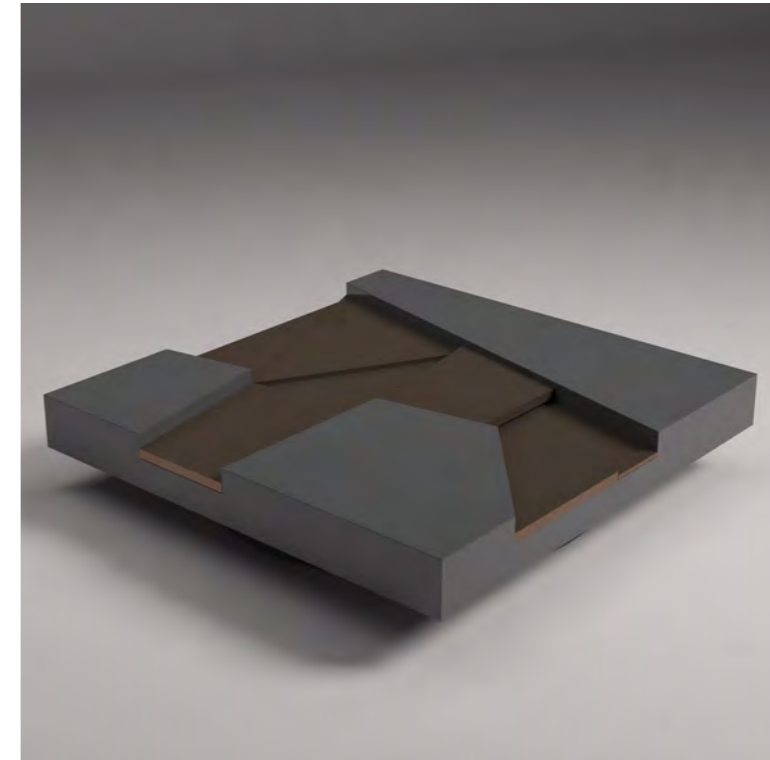



ABSOLUT BED

The Absolut bed is a celebration of softness and geometric rigor. The base and headboard are composed of long padding in the shape of semi-cylinders arranged in sequence, creating an eye-catching scenic effect. The upholstery in special fabrics or fine leathers is enriched with finishing stitching, which emphasizes the details of extraordinary craftsmanship. Workmanship now possible only in special laboratories. A perfect combination of comfort and design

Il letto Absolut è una celebrazione di morbidezza e rigore geometrico. La base e la testiera sono composte da lunghe imbottiture a forma di semi cilindri disposti in sequenza, creando un effetto scenico accattivante. Il rivestimento in tessuti speciali o pelli pregiate è arricchito da cuciture di rifinitura, che sottolineano i dettagli di straordinaria artigianalità. Lavorazioni ormai possibili solo in speciali laboratori. Una perfetta combinazione di comfort e design.



ABSOLUT CHAISE LONGUE

The Absolot chaise longue is engineered to deliver an ergonomic and high-performance relaxation experience, combining aesthetics and functionality in a single furnishing element. Its solid, precisely balanced structure supports a system of semi-cylindrical shaped paddings that ensure optimal comfort and support across the entire surface. The formal continuity of the design enhances the fluidity of its silhouette, while the choice of technical fabrics or fine leathers elevates its decorative and functional appeal. Precision stitching and tailored craftsmanship reflect the brand's manufacturing excellence. Designed for high-end residential and contract spaces, the Absolot chaise longue merges aesthetic sophistication, formal rigor, and advanced comfort.

La chaise longue Absolot è progettata per offrire una postazione di relax ergonomica e performante, integrando estetica e funzionalità in un unico elemento d'arredo. La struttura, solida e accuratamente calibrata, accoglie un sistema di imbottiture sagomate a semi cilindro che garantiscono comfort e sostegno ottimale lungo tutta la superficie. La continuità formale del design valorizza l'andamento fluido del profilo, mentre la selezione di rivestimenti in tessuti tecnici o pelli pregiate conferisce al prodotto un'elevata valenza decorativa e funzionale. Le cuciture di precisione e le lavorazioni sartoriali testimoniano l'eccellenza manifatturiera del brand. Pensata per ambienti residenziali e contract di alta gamma, la chaise longue Absolot è un complemento che coniuga ricercatezza estetica, rigore formale e comfort avanzato.

**ABSOLUT
CHAISE LONGUE**

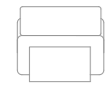
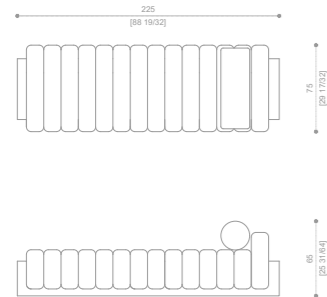

Chaise longue with solid/plywood frame and painted/lacquered MDF frame, padding in multi-density high resilience polyurethane foam. Leather or fabric upholstery.

Chaise longue con struttura in legno massello/ multistrato e struttura verniciata/laccata in MDF, imbottitura in poliuretano espanso densità differenziate, rivestimento in pelle o tessuto.





ABSOLUT BOOKCASE

Absolut Bookcase. An architectural composition that redefines the concept of storage. The Absolut bookcase unfolds as a sequence of hollowed-out and overlapping geometric volumes, creating a powerful visual rhythm. The shelves seem to emerge and re-enter the structure, creating a three-dimensional play of solids and voids. Made of precious wood essences or lacquered finishes, it is an element that combines functionality and sculptural design, ideal for environments with a strong contemporary style. An evolutionary and avant-garde design inherent in the DNA of the Tonino Lamborghini brand.

Libreria Absolut. Una composizione architettonica che ridefinisce il concetto di contenitore. La libreria Absolut si sviluppa come una sequenza di volumi geometrici scavati e sovrapposti, creando un ritmo visivo potente. I ripiani sembrano emergere e rientrare nella struttura, dando vita a un gioco tridimensionale di pieni e vuoti. Realizzata in essenze di legno pregiato o finiture laccate, è un elemento che coniuga funzionalità e design scultoreo, ideale per ambienti dallo stile deciso e contemporaneo. Un design evolutivo e avanguardista insito nel DNA del brand Tonino Lamborghini.

**ABSOLUT
BOOKCASE**

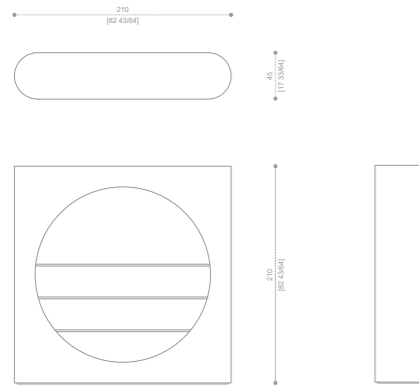

Bookcase in painted mdf with liquid metal finish, shelves covered in leather.

Libreria in mdf verniciato con finitura metallo liquido, ripiani rivestiti in pelle.





ABSOLUT BED SIDE TABLE

A stylish detail that completes the bedroom with a strong architectural imprint. The Absolut bedside table is characterised by its monolithic shape, which plays on volumes. The contrast between the rigorous geometry and the refined finishes – wood veneers, matt lacquers or metal finishes – make it a perfect accessory for rooms that seek a discreet but high-impact luxury. It is the perfect answer for those who prefer rooms where every aspect is decisive.

Un dettaglio di stile che completa la zona notte con un'impronta architettonica decisa. Il comodino Absolut si caratterizza per la sua forma monolitica, che lavora sui volumi. Il contrasto tra le geometrie rigorose e le finiture ricercate – essenze lignee, laccature opache o finiture in metallo – lo rendono un complemento, perfetto per ambienti che ricercano un lusso discreto ma di forte impatto. È la risposta perfetta per chi predilige ambienti dove ogni aspetto è decisivo.

**ABSOLUT
BED SIDE TABLE**

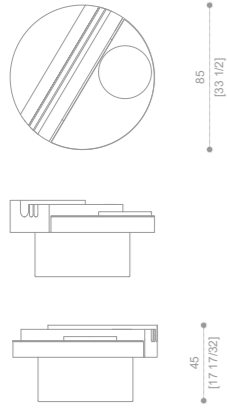

Bedside table with structure in painted/ lacquered MDF. with glass top.

Comodino con struttura in MDF vernicato/ laccato, piano in vetro.



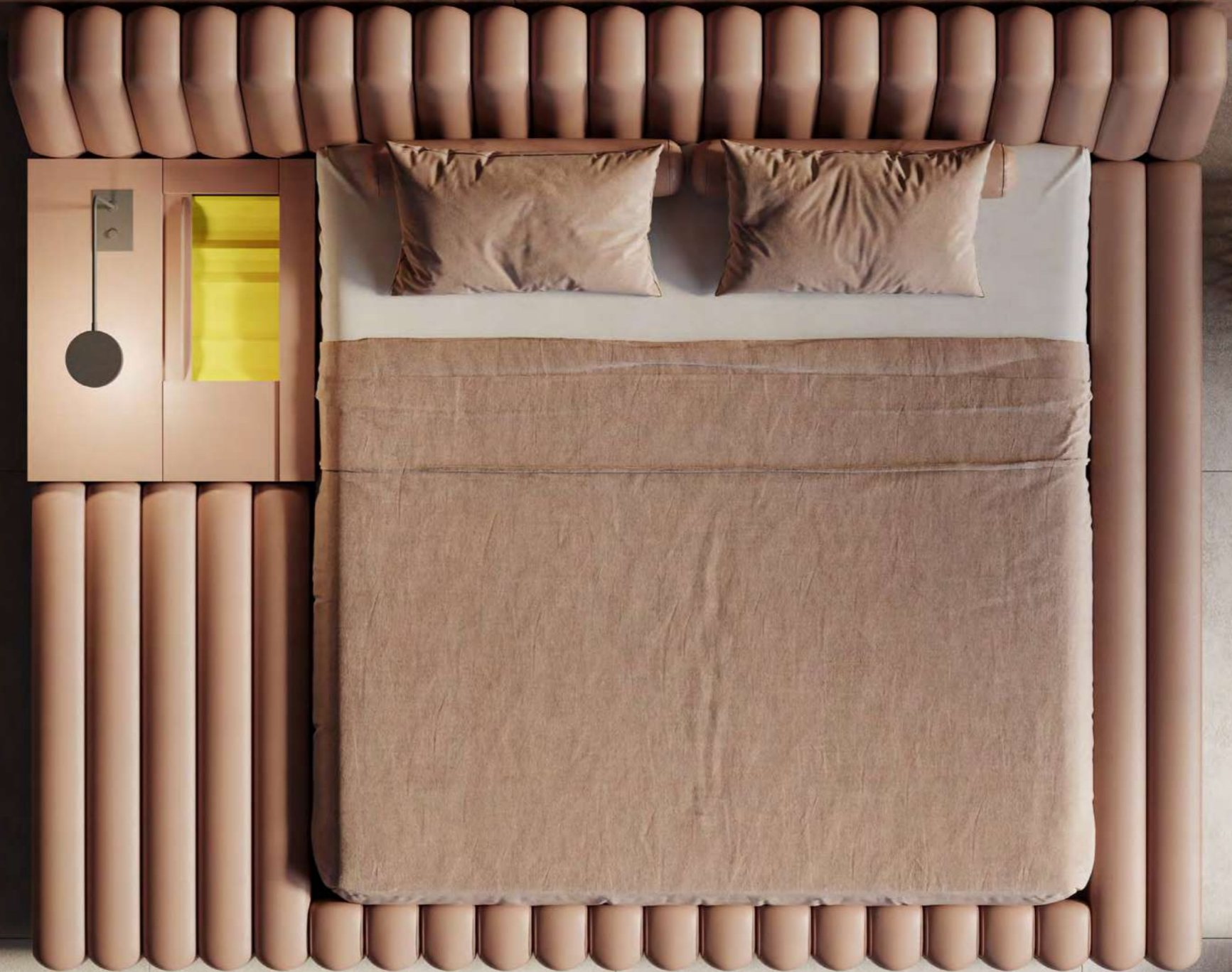



GRID

Grid Sofa 122

Grid Chaise 126

Grid Armchair 130

Grid Pouf 134

Grid Table 138

Grid Bed 142

Grid Side Tables 146

Grid Bedside Table 150

Essenz Armchair 154

Cylinder Coffee Table 158



GRID SOFA

The Grid sofa is the perfect embodiment of industrial aesthetics and timeless elegance. With its perforated metal base, this iconic piece evokes the dynamism of modern structures, but with a contemporary twist. The square seat is rigorously designed to enhance its bold character, while maintaining a sober linearity that makes it ideal for contemporary spaces. A design that discreetly and elegantly expresses style and functionality.

Il divano Grid è l'incarnazione perfetta dell'incontro tra estetica industriale ed eleganza senza tempo. Con una base in metallo traforato, questo pezzo iconico richiama il dinamismo delle strutture moderne, donando al contempo un tocco di modernità. La seduta squadrata, rigorosamente progettata per esaltarne il carattere deciso, al contempo mantiene una sobria linearità che lo rende ideale per spazi contemporanei. Un design che con discrezione e classe, sa esprimere stile e funzionalità.

**GRID
SOFA**

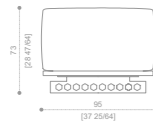
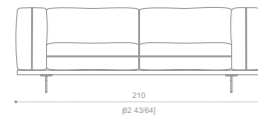

Sofa with solid wood/plywood structure with steel base and feet with hexagonal laser processing, padding in high resilience polyurethane foam, seat with elastic strap system. Upholstered in fabric or leather, metal painted side table.

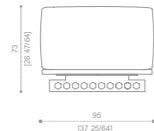
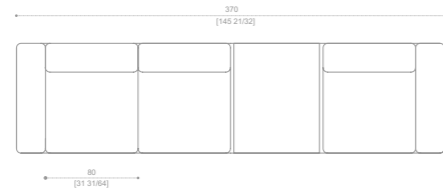
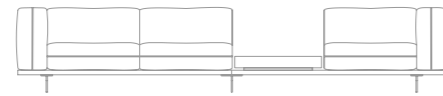

Divano con struttura in legno massello/multistrato con base e piedi in acciaio con lavorazione laser esagonale, imbottitura in poliuretano espanso densità differenziate, seduta con cinghie elastiche. Rivestimento in pelle o tessuto, tavolino verniciatura metallica.





GRID CHAISE

The Grid chaise combines a solid structure with a simple and dynamic look.

The perforated metal base, characterised by a refined geometric motif, guarantees stability and visual lightness, while the elongated seat follows an ergonomic profile designed to offer maximum comfort. The square and rigorous lines integrate perfectly with the structural identity of the collection, giving life to a sophisticated and functional element, ideal for contemporary spaces.

La chaise Grid combina una struttura solida con un'estetica essenziale e dinamica. La base in metallo traforato, caratterizzata da un raffinato motivo geometrico, garantisce stabilità e leggerezza visiva, mentre la seduta allungata segue un profilo ergonomico studiato per offrire il massimo comfort. Le linee squadrate e rigorose si integrano perfettamente con l'identità strutturale della collezione, dando vita a un elemento sofisticato e funzionale, ideale per spazi contemporanei.

**GRID
CHAISE**

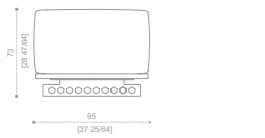
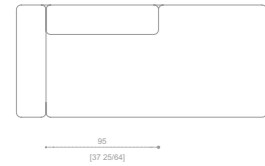
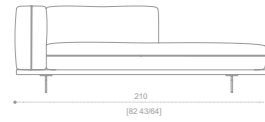

Chaise longue with solid wood/plywood structure with steel base and feet with hexagonal laser processing, padding in high resilience polyurethane foam, seat with elastic strap system. Upholstered in fabric or leather.

Chaise longue con struttura in legno massello/multistrato con base e piedi in acciaio con lavorazione laser esagonale, imbottitura in poliuretano espanso densità differenziate, seduta con cinghie elastiche. Rivestimento in pelle o tessuto.





GRID ARMCHAIR

The Grid armchair is a manifesto of modernity and character. The perforated metal base, with its bold and vibrant design, blends with a rigorous and comfortable seat, creating a perfect balance between aesthetic boldness and functionality. Ideal for cosmopolitan environments, it is an eye-catching piece that redefines the concept of relaxation with a contemporary language.

La poltrona Grid è un manifesto di modernità e carattere. La base in metallo traforato, dal design deciso e vibrante, si fonde con una seduta rigorosa e confortevole, creando un equilibrio perfetto tra audacia estetica e funzionalità. Ideale per ambienti cosmopoliti, è un pezzo che cattura lo sguardo e ridefinisce il concetto di relax con un linguaggio contemporaneo.

**GRID
ARMCHAIR**

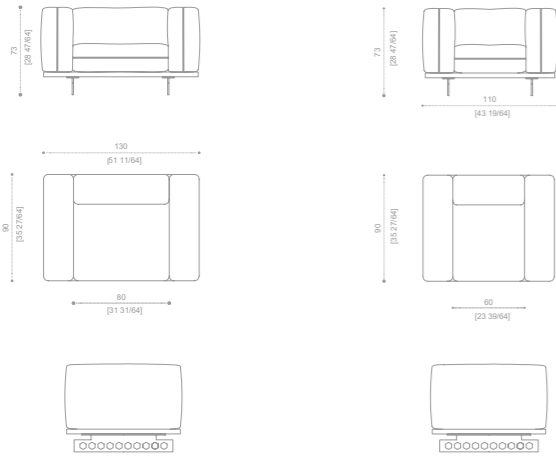

Armchair with solid wood/plywood structure with steel base and feet with hexagonal laser processing, padding in high resilience polyurethane foam, seat with elastic strap system. Upholstered in fabric or leather.

Poltrona con struttura in legno massello/multistrato con base e piedi in acciaio con lavorazione laser esagonale, imbottitura in poliuretano espanso densità differenziate, seduta con cinghie elastiche. Rivestimento in pelle o tessuto.





GRID POUF

The Grid pouf, with its essential geometric lines and perforated base, stands out for its versatility and style. It is a complement that combines visual lightness and substance, perfect to enrich any space with a touch of innovation and comfort, in line with the bold spirit of the collection.

Il pouf Grid, con le sue linee geometriche essenziali e la base traforata, si distingue per versatilità e stile. È un complemento che unisce leggerezza visiva e sostanza, perfetto per arricchire qualsiasi spazio con un tocco di innovazione e comfort, in linea con lo spirito audace della collezione.

**GRID
POUF**

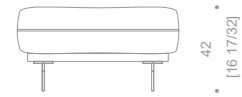

**Pouf with solid wood/
plywood structure with
steel base and feet
with hexagonal laser
processing, padding
in high resilience
polyurethane foam, seat
with elastic strap system.
Upholstered in fabric or
leather.**

*Pouf con struttura
in legno massello/
multistrato con base
e piedi in acciaio con
lavorazione laser
esagonale, imbottitura
in poliuretano espanso
densità differenziate,
seduta con cinghie
elastiche.*

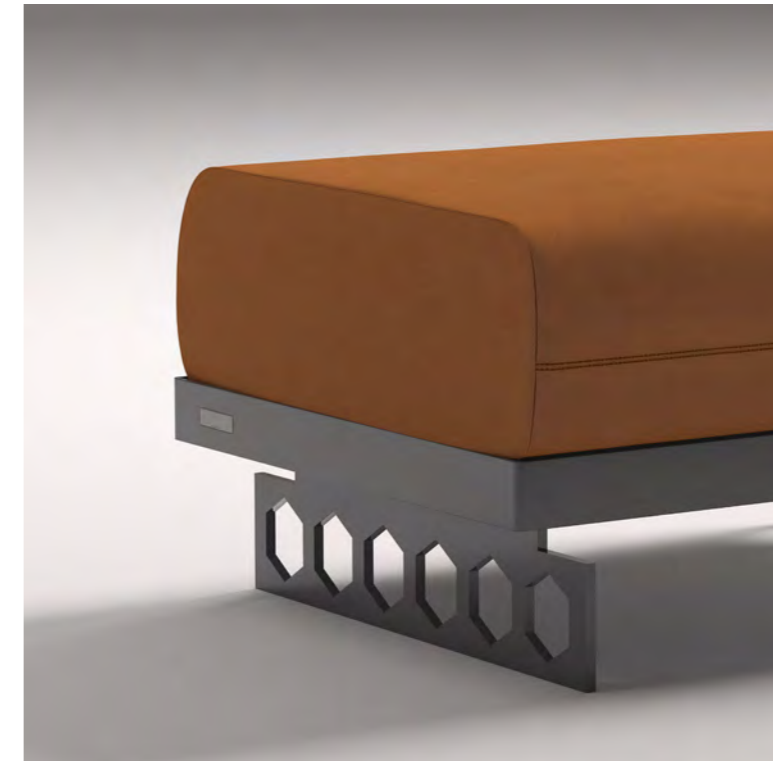



GRID TABLE

The Grid table is a bold and sophisticated interpretation of three-dimensional forms, where the elegance of marble merges with the purity of proportions. The hexagonal top, with its soft curves, rests on a base that evokes the precision of polyhedral structures, with two pointless hexagons joining to form a perfect parallelepiped. A design that celebrates the harmony of form and the art of spatial composition, creating a piece of furniture that perfectly combines design and innovation.

Il tavolo Grid è un'interpretazione audace e sofisticata delle forme tridimensionali, dove l'eleganza del marmo si fonde con la purezza delle proporzioni. Il top esagonale, dalle curve morbide, si poggia su una base che evoca la precisione delle strutture poliedriche, con due esagoni senza punta che si uniscono in un perfetto parallelepipedo. Un design che celebra l'armonia delle forme e l'arte della composizione spaziale, creando un pezzo di arredamento che unisce design e innovazione in modo impeccabile.

**GRID
TABLE**

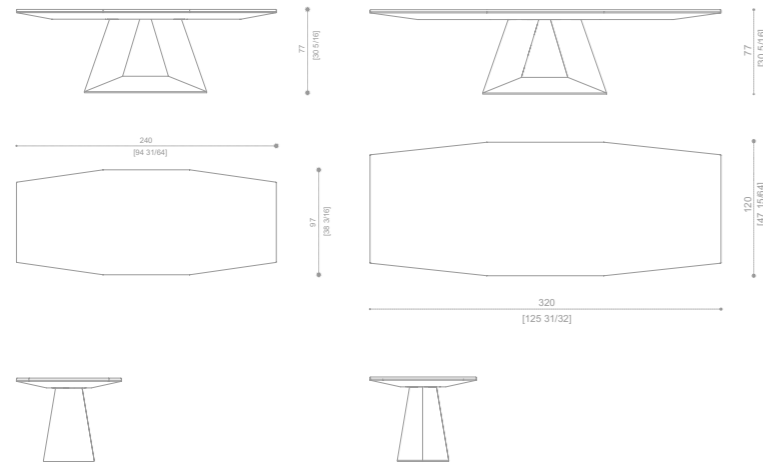

Dining table with marble, walnut or lacquered top. Metal and MDF structure lacquered or covered in leather.

Tavolo pranzo con top in marmo, in legno di noce o laccato. Struttura in metallo ed MDF laccata o rivestita in pelle.





GRID BED

The Grid bed is an innovative fusion of quality and design. The strength of metal meets the purity of minimalist lines. The bed base is the distinguishing element; made of perforated metal, it recalls modern geometries and, despite its strength, expresses lightness. The bed frame, including the headboard, with its square and rigorously architectural lines, adds a touch of refined avant-garde to the environment, perfect for those looking for a piece of furniture that goes beyond function to become the centre of the room. A bed that expresses the harmony between industrial materials and refined details, designed for modern spaces that combine aesthetics and comfort without compromise.

Il letto Grid rappresenta un'innovativa fusione di qualità e design. La forza del metallo incontra la purezza delle linee minimaliste. La base di appoggio è l'elemento di distinzione; in metallo traforato, richiama le geometrie moderne, e pur nella sua robustezza, esprime leggerezza. La struttura del letto compresa la testiera, dalle linee squadrate e rigorosamente architettate, arricchiscono l'ambiente con un accento di sofisticato avanguardismo, perfetto per chi cerca un arredo che vada oltre la funzione e diventi la centralità dell'ambiente. Un letto che esprime un'armonia tra materiali industriali e dettagli ricercati, pensato per spazi moderni che uniscono estetica e comfort senza compromessi.

**GRID
BED**

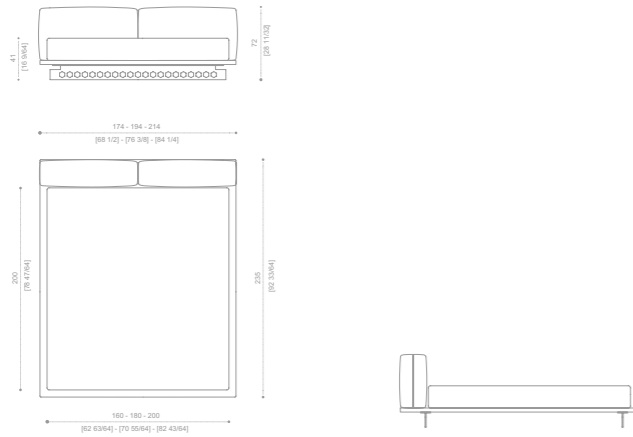

Bed with laser-worked steel structure, headboard structure in solid wood and/or plywood, padded with polyurethane foam. Headboard upholstered in fabric or leather.

Letto con struttura in acciaio lavorato al laser, testa letto struttura in legno massello e/o multistrato, imbottita in poliuretano espanso. Testa letto rivestito in tessuto o pelle.





GRID SIDE TABLES

Grid coffee tables are a perfect meeting between the timelessness of marble and the modernity of metal structure. The base, formed by metal hexagons that resemble a three-dimensional net, supports a round top in fine marble, a symbol of perfection and refinement. The combination of this architecture – the circle and the hexagonal net – creates a strong visual identity. Available in two heights, they can also be enriched with a storage drawer placed under the top, adding a touch of luxury and hyper refinement.

I tavolini Grid sono un perfetto incontro tra la materia senza tempo, il marmo, e la modernità della struttura metallica. La base, formata da esagoni in metallo che richiamano una rete tridimensionale, sostiene un top rotondo in marmo pregiato, simbolo di perfezione e raffinatezza. La combinazione di questa architettura – il cerchio e la rete esagonale – crea una forte identità visiva. Disponibili in due altezze, hanno anche la possibilità di essere arricchiti da un cassetto contenitore posto sotto il top, aggiungere un tocco di lusso e iper ricercatezza.

**GRID
SIDE TABLES**

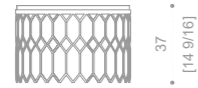
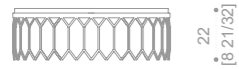
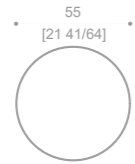
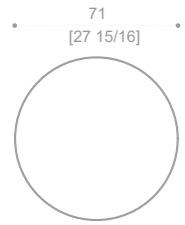

Coffee and side table
with painted steel base
and wooden or marble
top.

*Tavolini con base in
acciaio verniciato con
top in legno o marmo.*





GRID BEDSIDE TABLE

The Grid bedside table is a fusion of energetic refinement, where material is transformed into a striking structure. The cylindrical base, composed of a hexagonal metal weave, creates a dramatic, almost ethereal three-dimensional effect. The wooden top, with its integrated drawer, adds a sophisticated material contrast, making this piece an icon of style and functionality. Grid is an innovative and cosmopolitan element that adds a design accent to the bedroom.

Il comodino Grid è una fusione di dinamismo e raffinatezza, dove la materia si trasforma in struttura d'impatto. La base cilindrica, composta da un intreccio esagonale in metallo, crea un effetto tridimensionale audace, quasi etereo. Il top in legno, con il suo cassetto integrato, aggiunge un contrasto materico sofisticato, rendendo questo pezzo un'icona di stile e funzionalità. Grid è un elemento innovativo e cosmopolita che aggiunge un accento di design alla camera da letto.

**GRID
BEDSIDE TABLE**

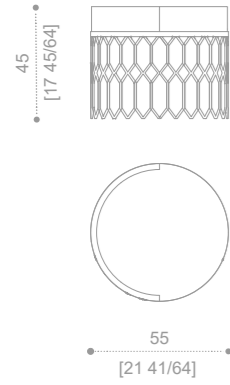

Bedside table with
painted steel base with
wooden top and drawer.

*Comodino con base in
acciaio verniciato con
top in legno e cassetto.*





ESSENZ ARMCHAIR

A refined balance of form and lightness, this armchair is defined by a sculptural backrest that extends seamlessly to the ground, curving outward in a fluid and accentuated gesture. The inclined line creates a continuous surface that wraps around and supports the body, transitioning into a linear, elegant backrest. The structure is solid yet visually light, with a thin, precisely shaped padding that preserves the armchair's minimal silhouette while ensuring comfort. With its clean lines and measured proportions, this piece is ideal for sophisticated settings where every detail reflects a harmony of aesthetics, function, and visual lightness. An armchair that embodies both graphic precision and architectural expression.

Si distingue per lo schienale scultoreo che si estende fino a terra, curvandosi elegantemente verso l'esterno. Questa linea inclinata genera una superficie continua che avvolge e accoglie, trasformandosi in un raffinato sostegno per la schiena. La struttura è solida ma visivamente snella, mentre l'imbottitura, sottile e calibrata, contribuisce a mantenere un profilo essenziale senza compromettere il comfort. Le proporzioni misurate e il disegno pulito rendono questo elemento d'arredo perfetto per ambienti sofisticati, dove ogni dettaglio è pensato per fondere estetica, funzionalità e leggerezza visiva. Una poltrona che è al tempo stesso segno grafico e gesto architettonico.

ESSENZ ARMCHAIR

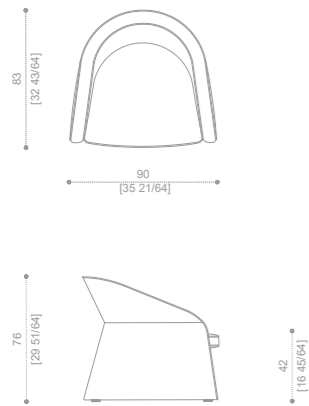

Armchair with plywood structure covered with high resilience and variable density polyurethane foam. Upholstered in fabric or leather.

Poltrona con struttura in multistrato di legno, imbottiture in poliuretano espanso a densità differenziate, rivestimento in tessuto o pelle.





CYLINDER COFFEE TABLE

These low tables pay homage to the strength and precision of industrial geometry. The shape reminiscent of a stylized bolt is reinterpreted with nonchalant sophistication in metal, creating a solid and original design object that plays on the intersection of art and engineering.

Questi tavolini rendono omaggio alla forza e alla precisione della geometria industriale. La forma che richiama un bullone stilizzato è reinterpretata con disinvolta eleganza in metallo, creando un oggetto di design robusto e originale che gioca sull'intersezione tra arte e ingegneria.

**CYLINDER COFFEE
TABLE**

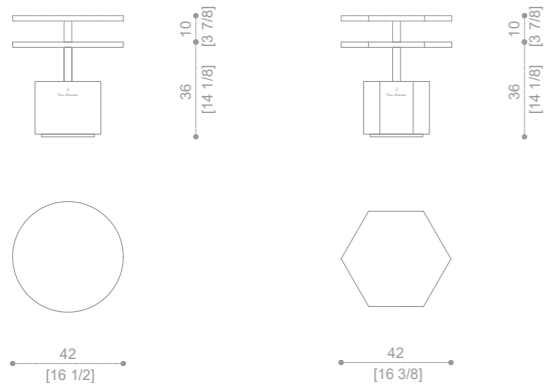

Polished stainless
steel coffee table with
variable height shelf.

*Tavolo da caffè in acciaio
inox lucido con ripiano
ad altezza variabile.*





FRACTAL

Fractal Sofa	168
Fractal Chaise	172
Fractal Pouf	176
Fractal Chair	180
Fractal Meteor	184
Fractal Table	188
Fractal Bed	192
Fractal Dormeuse	196
Pattern Coffee Table	200



FRACTAL SOFA

Embodies the power of geometry, where the triangle, a symbol of balance and harmony, gives birth to an innovative seat. The irregular shapes that come together in a dynamic interplay of triangles and planes create a feeling of reformist modernity and unparalleled comfort.

Incarna la potenza della geometria, dove il triangolo, simbolo di equilibrio e armonia, dà vita a una seduta innovativa. Le forme irregolari che si uniscono in un gioco dinamico di triangoli e piani creano una sensazione di modernità riformista e comfort senza pari.

**FRACTAL
SOFA**

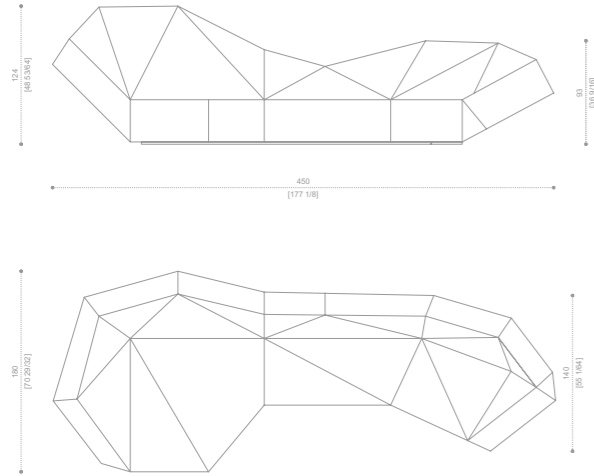

Sofa with metal structure, padding in differentiated density polyurethane foam, upholstered with leather or fabric.

Divano con struttura in metallo, imbottiture in poliuretano espanso a densità differenziate, rivestimento in pelle o tessuto.





FRACTAL CHAISE

Fractal chaise longue is an installation that transforms the space, blending aesthetics and functionality into an unparalleled relaxation experience.

Fractal chaise longue è un'installazione che trasforma lo spazio, fondendo estetica e funzionalità in un'esperienza di relax senza pari.

**FRACTAL
CHAISE**

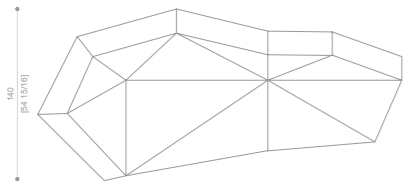
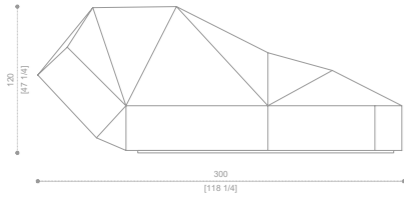

Chaise longue with metal structure, padding in differentiated density polyurethane foam, upholstered with leather or fabric.

Chaise longue con struttura in metallo, imbottiture in poliuretano espanso a densità differenziate, rivestimento in pelle o tessuto.





FRACTAL POUF

A fragment of architecture transformed into a furnishing accessory. The Fractal pouf embodies the essence of line, with its sculpted surfaces and dynamic intersection of triangles creating a faceted, sculptural volume. Upholstered in fine top-grain leather, every detail is designed to enhance the handcrafted quality and materiality, while the stitching emphasises its geometric precision. A versatile piece that can stand alone as a design element or complete the composition of the other furnishings in the collection, bringing a touch of avant-garde and refinement to spaces.

Un frammento di architettura trasformato in complemento d'arredo. Il pouf Fractal incarna l'essenza della linea, con le sue superfici scolpite e l'intersezione dinamica di triangoli che creano un volume sfaccettato e scultoreo. Rivestito in pregiata pelle primo fiore, ogni dettaglio è studiato per esaltare la qualità artigianale e la matericità, mentre le cuciture ne sottolineano la precisione geometrica. Un pezzo versatile, che può vivere da solo come elemento di design o completare la composizione degli altri arredi della collezione, portando negli spazi un tocco di avanguardia e raffinatezza.

**FRACTAL
POUF**

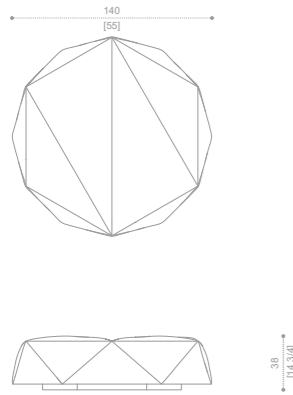

Pouf with metal structure, padding in differentiated density polyurethane foam, upholstered with leather or fabric.

Pouf con struttura in metallo, imbottiture in poliuretano espanso a densità differenziate, rivestimento in pelle o tessuto.





FRACTAL CHAIR

Geometry and lightness come together in a perfect balance of aesthetics and functionality. The Fractal chair reinterprets the concept of seating through a dynamic and sculptural design, in which the four-spoke metal support structure guarantees stability and visual impetus. The seat, upholstered in fine leather, envelops with elegance and comfort, enhancing the dialogue between noble materials and formal rigour. The broken lines and clear-cut contours create a vibrant visual effect, making it an iconic element that fits effortlessly into contemporary settings and spaces with a futuristic soul.

Geometria e leggerezza si fondono in un equilibrio perfetto tra estetica e funzionalità. La sedia Fractal reinterpreta il concetto di seduta attraverso un design dinamico e scultoreo, in cui la struttura portante in metallo a quattro razze garantisce stabilità e slancio visivo. La seduta, rivestita in pelle pregiata, avvolge con eleganza e comfort, esaltando il dialogo tra materiali nobili e rigore formale. Le linee spezzate e i profili netti creano un effetto visivo vibrante, rendendola un elemento iconico che si inserisce con disinvoltura in ambienti contemporanei e spazi dall'anima futuristica.

**FRACTAL
CHAIR**

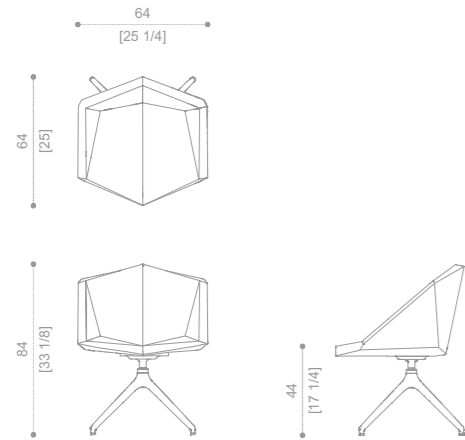

Chair with metal structure, padding in differentiated density polyurethane foam, upholstered with leather or fabric.

Sedia con struttura in metallo, imbottitura in poliuretano espanso a densità differenziate, rivestimento in pelle o tessuto.



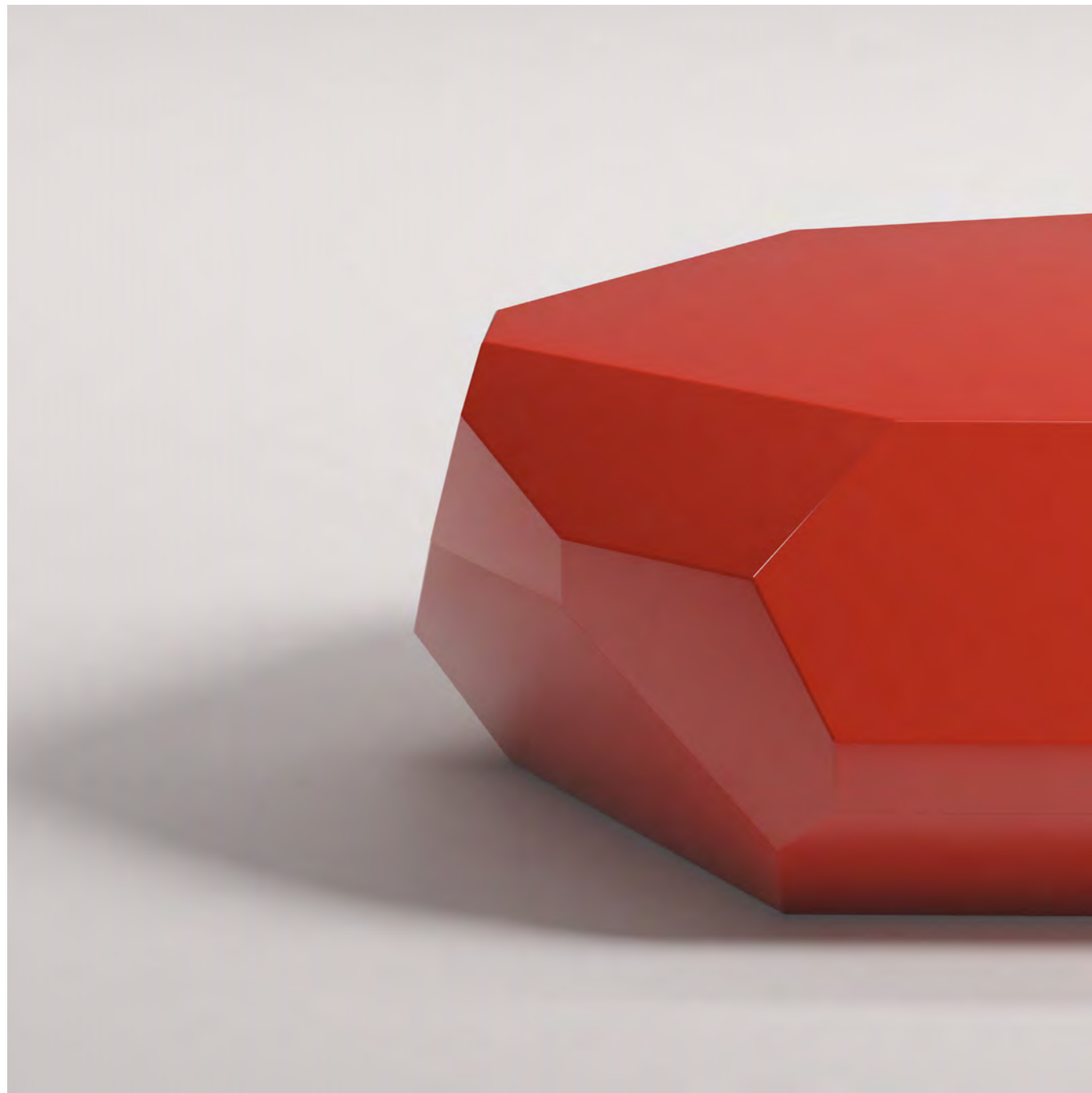

FRACTAL METEOR

An object that challenges convention, transforming matter into pure geometric expression. The Fractal Coffee Table retains the iconic lines of the collection, with faceted volumes inspired by the intersection of irregular triangles, but reinterprets them through the solidity and brilliance of the glossy painted surfaces. The reflective surface amplifies the perception of the shapes, creating plays of light and depth that enhance the sculptural structure. The Fractal Coffee Table is designed for those seeking a balance between art and functionality, formal avant-garde and material warmth.

Un oggetto che sfida le convenzioni, trasformando la materia in pura espressione geometrica. Il Fractal Coffee Table riprende le linee iconiche della collezione, con volumi sfaccettati ispirati all'intersezione di triangoli irregolari, ma le reinterpreta attraverso la solidità e la brillantezza delle superfici verniciate lucide. La superficie riflettente amplifica la percezione delle forme, creando giochi di luce e profondità che ne esaltano la struttura scultorea. Il Fractal Coffee Table è pensato per chi cerca un equilibrio tra arte e funzionalità, avanguardia formale e calore materico.

**FRACTAL
METEOR**

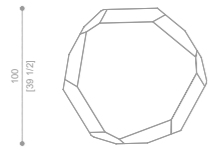

Coffee table with resined
EPS structure.

*Tavolino con struttura in
eps resinato.*





FRACTAL TABLE

The Fractal Table stands out for its balance of visual lightness and structural solidity. The sophisticated and refined smoked satin glass top rests delicately on a base that is a true work of art: a dynamic network of intertwined metal triangles, recalling the harmony and power of Fractal design. Every detail is designed to create a sense of movement, with lines intersecting in a perfect geometric dance. A piece of furniture that transforms space, blending elegance and innovation. The Fractal table is the pure expression of the balance between form and function.

Il Tavolo Fractal si distingue per il suo equilibrio tra leggerezza visiva e solidità strutturale. Il top in vetro satinato fumé, sofisticato e raffinato, si posa delicatamente su una base che è una vera opera d'arte: una rete dinamica di triangoli metallici intrecciati, che richiama l'armonia e la potenza del design Fractal. Ogni dettaglio è studiato per creare un senso di movimento, con linee che si intersecano in una danza geometrica perfetta. Un elemento di arredo che trasforma lo spazio, fondendo eleganza e innovazione. Il tavolo Fractal è l'espressione pura dell'equilibrio tra forma e funzione.

**FRACTAL
TABLE**

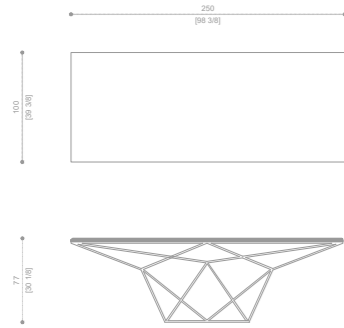

Dining table with top
in glass 20 mm thick
and base in metallic
structure.

*Tavolo da pranzo con
piano in vetro spessore
20 mm e base in
struttura metallica.*





FRACTAL BED

Fractal Bed embodies the perfect fusion of artisanal mastery and contemporary innovation. Its base, upholstered in premium full-grain leather, is enhanced by exposed stitching that highlights the attention to detail and expert use of traditional craftsmanship. The structure unfolds in a distinctive geometry: elongated triangles that support the mattress with elegance and stability, creating a sculptural, eye-catching silhouette. The headboard, also upholstered in leather, completes the design with a refined and airy presence, giving the bed an almost lunar character.

Fractal Bed rappresenta l'incontro tra maestria artigianale e innovazione contemporanea. La base, rivestita in pregiata pelle pieno fiore, è valorizzata da cuciture a vista che esaltano l'attenzione al dettaglio e il sapiente impiego di tecniche tradizionali. La struttura si articola in una geometria originale: triangoli allungati che sostengono il materasso con eleganza e solidità, generando una silhouette scultorea e iconica. La testiera, anch'essa rivestita in pelle, completa la composizione con una presenza sofisticata e leggera, donando al letto un carattere quasi lunare.

**FRACTAL
BED**

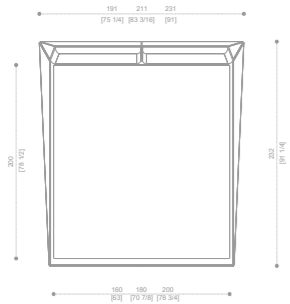

Bed with wooden structure completely padded, upholstered with leather or fabric. Base in painted wood.

Letto con struttura in legno completamente imbottito e rivestito in pelle o tessuto. Base in legno verniciato.

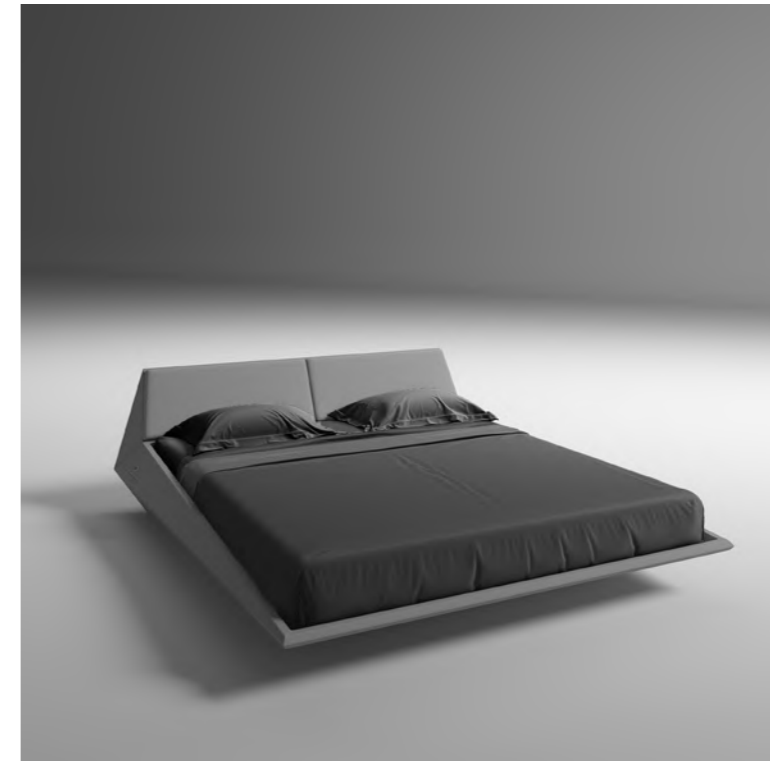

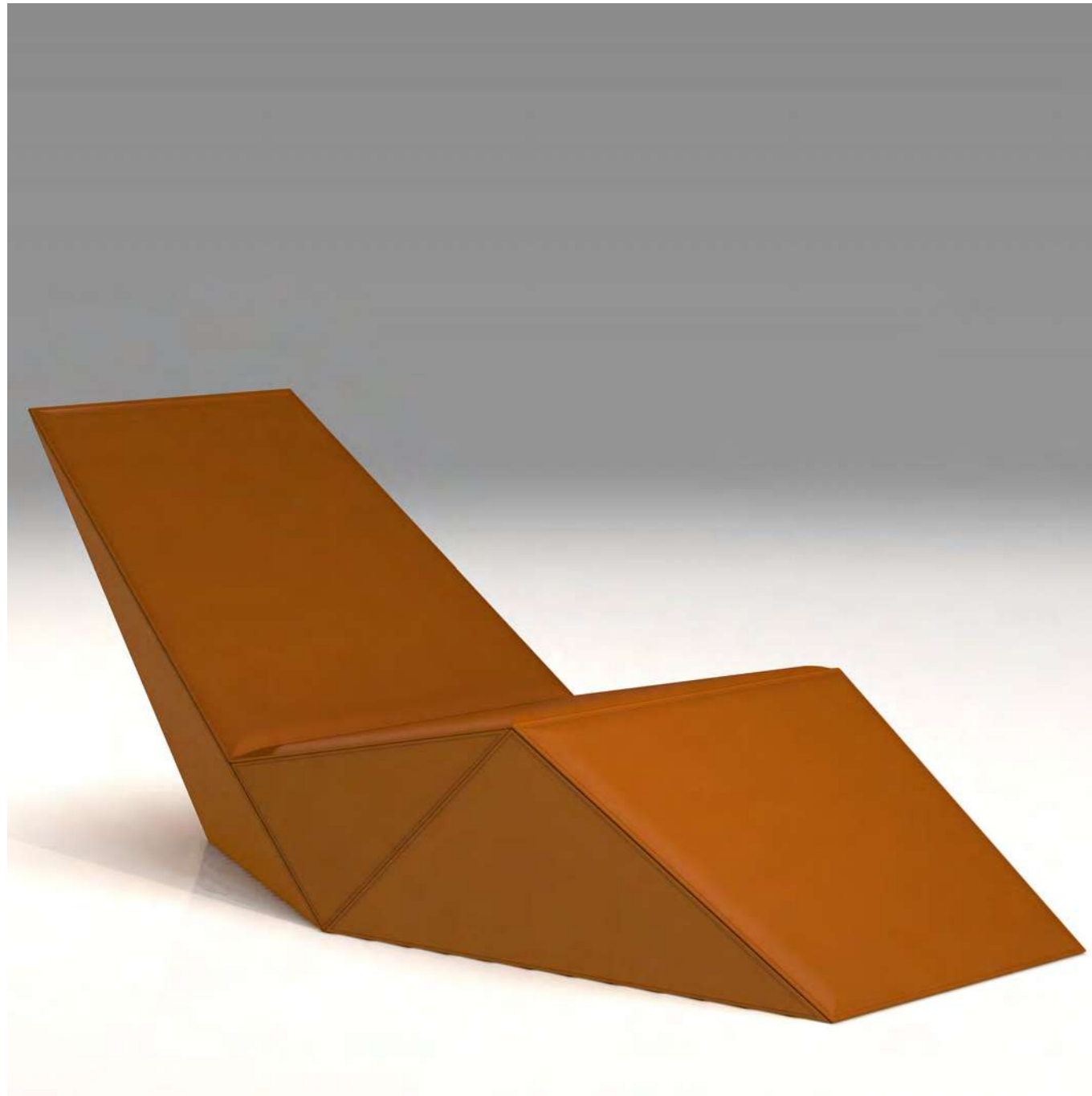

FRACTAL DORMEUSE

A perfect balance between geometry and comfort, a piece that sublimates form for the purpose of relaxation. Sloping surfaces and broken lines come together in a refined design, welcoming the body into a natural posture. The rhythm of its forms creates a sculptural landscape that furnishes the space with personality, making each break an aesthetic and sensorial experience, a visual poem.

Equilibrio perfetto tra geometria e comfort, un'opera che sublima la forma in funzione del riposo. Le superfici inclinate e le linee spezzate si incontrano in un disegno raffinato, per accogliere il corpo in una postura naturale. Il ritmo delle sue forme crea un paesaggio scultoreo che arreda lo spazio con personalità, rendendo ogni pausa un'esperienza estetica e sensoriale, una poesia visiva.

**FRACTAL
DORMEUSE**

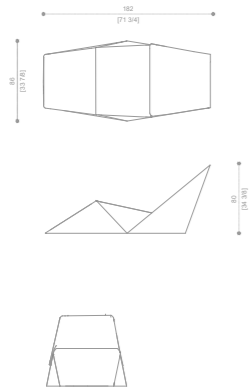

Chaise longue with
painted EPS structure
covered in leather.
Cushion covered in
leather or fabric.

*Chaise longue con
struttura in EPS
verniciato e rivestita in
pelle. Cuscino rivestito in
pelle o tessuto.*

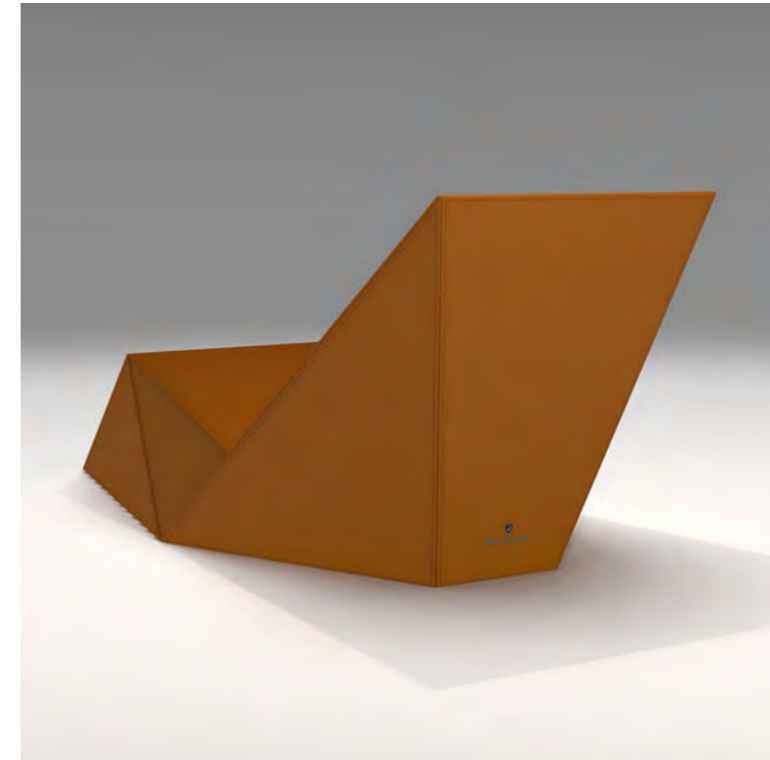



PATTERN COFFEE TABLE

Compact yet charged with formal tension, Pattern coffee table transforms a simple square footprint into a composition of interlocking and shifting volumes. The tabletop breaks apart and reassembles, giving shape to a micro-architecture carved in space. Designed to stand alone or in dialogue with other elements of the same family, it lends itself to ever-changing configurations and domestic landscapes. The balance between solids and voids, between stability and movement, creates a refined object that merges geometric rigor with expressive freedom.

Compatto ma carico di tensione formale, Pattern coffee table articola una semplice pianta quadrata in una composizione di volumi incastrati e slittati. La superficie d'appoggio si frammenta e si ricompone, dando forma a una microarchitettura scolpita nello spazio. Pensato per vivere da solo o in dialogo con altri elementi della stessa famiglia, si presta a configurazioni mutevoli e a paesaggi domestici sempre diversi. L'equilibrio tra pieni e vuoti, tra stabilità e movimento, genera un oggetto misurato, capace di fondere rigore geometrico e libertà espressiva.



TECTON COLLECTION



TECTON CABINET

A piece of furniture that seems to be generated by a slow tectonic movement, as if masses of wooden material had pushed against each other until they found a balance. The contrast between different woods - by colour, grain, density - defines the geometry of the whole, emphasising every fracture and every line of contact. The articulation of volumes is sharp but never rigid, suggesting an internal tension that is reflected on the outside. Tecton Cabinet imposes itself as an autonomous form, composed but in continuous vibration.

Un mobile che sembra generarsi da un lento movimento tettonico, come se masse di materia lignea si fossero spinte l'una contro l'altra fino a trovare un equilibrio. Il contrasto tra essenze diverse - per colore, venatura, densità - definisce la geometria dell'insieme, sottolineando ogni frattura e ogni linea di contatto. L'articolazione dei volumi è netta ma mai rigida, capace di suggerire una tensione interna che si riflette all'esterno. Tecton Cabinet si impone come forma autonoma, composta ma in continua vibrazione.

TECTON CABINET

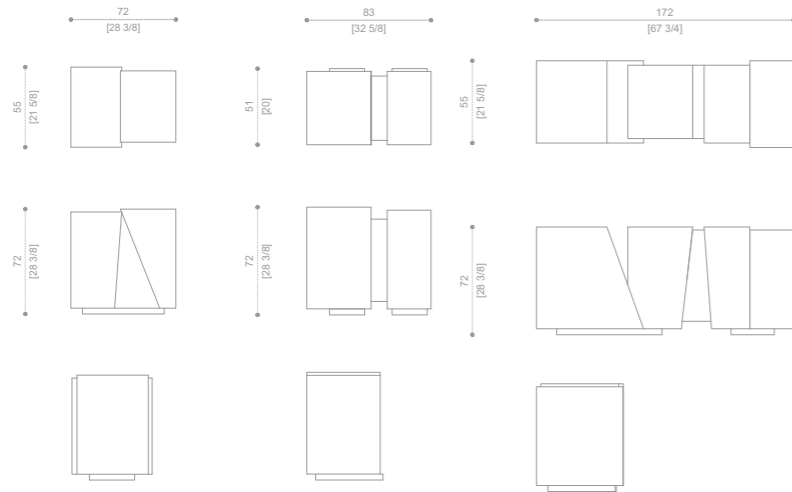

**Composable cabinet
in solid wood various
essences.**

*Credenza componibile
in legno massello varie
essenze.*





TECTON BEDSIDE TABLE

Tecton is born from the calibrated encounter between pure volumes and contrasting textures. The juxtaposition of different types of wood - in tone, grain and depth - generates a visual play of discontinuities and unexpected alignments. The object, compact and measured, seems to derive from a tectonic shift, as if its elements had shifted with respect to each other, yet maintaining a cohesive tension. Designed to live alone or in dialogue with other pieces in the same series, Tecton defines a domestic landscape of stratifications, intersections and minor frictions.

Tecton nasce dall'incontro calibrato tra volumi puri e matericità contrastanti. L'accostamento di essenze lignee differenti — per tono, grana e profondità — genera un gioco visivo fatto di discontinuità e allineamenti inattesi. L'oggetto, compatto e misurato, sembra derivare da uno spostamento tettonico, come se i suoi elementi si fossero slittati l'uno rispetto all'altro, mantenendo però una tensione coesa. Disegnato per vivere da solo o in dialogo con altri pezzi della stessa serie, Tecton definisce un paesaggio domestico fatto di stratificazioni, intersezioni e piccoli attriti.

**TECTON BEDSIDE
TABLE**

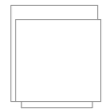
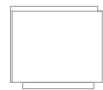
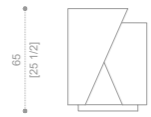
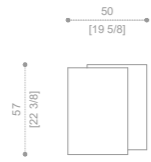
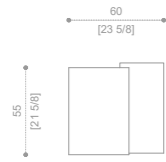

Composable bed side
table in solid wood
various essences.

*Comodino componibile
in una selezione di
essenze di legno.*





TECTON COFFEE TABLE

More than just a coffee table, Tecton coffee table is a composition of solid geometric forms crafted from a selection of fine, precious woods. Each element is placed or joined with thoughtful precision, creating sculptural pieces that merge function with artistry.

The design doesn't dictate—it invites. It leaves space for the imagination of those who observe, use, and interpret it. Tecton is a versatile and valuable object, capable of transforming depending on the context and the unique perspective of those who welcome it into their space.

Un'opera che trascende il concetto di semplice tavolino: Tecton coffee table è una composizione di figure geometriche solide, realizzate in essenze lignee pregiate e di diversa provenienza. Ogni elemento si accosta o si unisce agli altri con precisione e armonia, dando vita a sculture funzionali che arredano con eleganza e significato.

Il design non si impone, ma invita: lascia spazio all'immaginazione di chi osserva, di chi usa, di chi interpreta. Tecton è un oggetto d'arredo versatile e prezioso, capace di trasformarsi a seconda del contesto e dello sguardo, sempre unico, di chi lo accoglie nel proprio spazio.

TECTON COFFEE TABLE

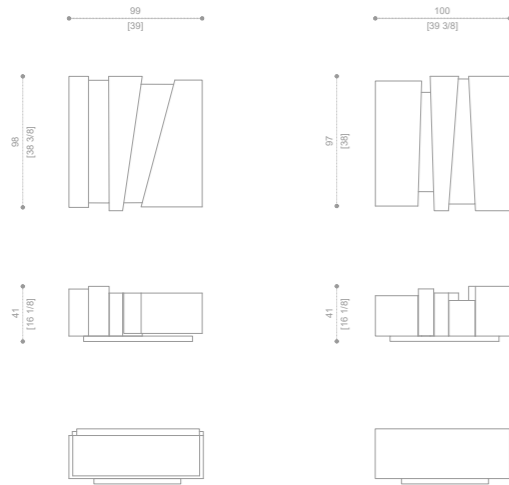

**Composable coffee table
in solid wood various
essences.**

*Tavolino da caffè
componibile in legno
massello varie essenze.*



Ricardo Antonio, Brazilian designer and founder of RADS Studio, in collaboration with ZL Design Group, has created a new furniture collection for the prestigious Tonino Lamborghini brand, with which he redefines the language of design, combining aesthetics and research. Inspired by the Space Age, but projected towards new scenarios, the collection sculpts space with decisive volumes, refined surfaces and innovative materials. Each element is a fusion of geometric rigour and versatility, designed for environments that go beyond conventions and anticipate new visions of contemporary living. Ricardo Antonio began his professional life at Modulo, a Brazilian architecture and art monthly magazine, managed by the master of Brazilian modernist architecture Oscar Niemeyer, with whom he began a lifelong friendship and collaboration. The close contact with Niemeyer and most of the Brazilian modernist masters of the 'Brasilia Generation', had a decisive impact on Ricardo Antonio's training. In 1990 he opened his Studio URB in Rio, where he designed and produced a series of award-winning pieces of furniture. He later moved to Europe, and in the early 2000s he worked as a freelance journalist in London for international architecture and design magazines. At the same time he created a series of unique

pieces and collaborated with Oscar Niemeyer on projects such as the Serpentine Pavilion (London 2003) and the Oscar Niemeyer Auditorium in Ravello (Italy 2000 – 2010). In 2003, his award-winning Ravello seating range became his first design to be distributed on a global scale, by the prominent Italian manufacturer Poltrona Frau. 'La Ravello' is now part of the permanent collection of the Chair Museum in Rio.

Ricardo Antonio, designer brasiliano, fondatore dello Studio RADS, in collaborazione con ZL Design Group ha realizzato per il prestigioso brand Tonino Lamborghini, una nuova collezione di arredi con i quali ridefinisce il linguaggio del design, intrecciando estetica e ricerca. Ispirata alla Space Age, ma proiettata verso scenari inediti, la collezione scolpisce lo spazio con volumi decisi, superfici raffinate e materiali innovativi. Ogni elemento è una fusione di rigore geometrico e versatilità, pensata per ambienti che superano le convenzioni e anticipano nuove visioni dell'abitare contemporaneo. Ricardo Antonio inizia la sua vita professionale presso Modulo, mensile brasiliano di architettura e arte, gestito dal maestro architetto modernista brasiliano Oscar Niemeyer, con il quale inizia un'amicizia e una collaborazione per tutta la vita. Lo stretto contatto con Niemeyer e la maggior parte dei maestri modernisti brasiliani della "Generazione Brasilia" avrà un impatto decisivo sulla formazione di Ricardo Antonio. Nel 1990 apre il suo Studio URB, a Rio, dove progetta e realizza una serie di mobili pluripremiati. Trasferitosi successivamente in Europa, nei primi anni 2000 da Londra collabora come giornalista freelance con riviste internazionali di architettura e design. Parallelamente crea una serie di pezzi unici e collabora con Oscar Niemeyer in pro-

getti come il Serpentine Pavillion (Londra 2003) e l'Auditorium Oscar Niemeyer, a Ravello (Italia 2000 – 2010). Nel 2003, la sua premiata gamma di sedute Ravello diventa il suo primo progetto ad essere distribuito su scala globale, dall'importante produttore italiano Poltrona Frau. "La Ravello" fa oggi parte della collezione permanente del Museo della Sedia di Rio.

Under licence of
Su licenza di

TONINO LAMBORGHINI SPA
www.lamborghini.it
info@lamborghini.com

Zona Living Srl
info@zonaliving.it
info@zldesgingroup.it
Viale Europa, 91 - 51034 Casalguidi
Serravalle P.se (PT)
Tel. 0039 0573 527951

We would like to thank Mrs. Angela
Krieger for the creative consultancy.

*Si ringrazia la Signora Angela Krieger
per la consulenza creativa.*





Tonino Lamborghini

TOTAL LIVING